

SCOTSMAN®

Automatic Air and Water Cooled Nugget Ice Maker/Dispenser

ITEM NO.

NDE750

C.S.I. File No. 11400



NUGGET ICE

Versatile, inexpensive to produce, used in carbonated beverages and salad bars.



TOP BEARING

Extra large top bearing attached to auger and breaker reduces bearing wear.

The NDE750 represents a totally new concept in the manufacture of the already popular Scotsman Nugget Ice – new components – from design to materials.

LONG SERVICE LIFE

- Evaporator, auger and breaker are all fabricated from durable stainless steel.
- Innovative “Interrupted Flight” auger design minimizes bearing loads.
- New gearmotor design includes heavy duty ball bearings.
- Large spherical top roller bearing self aligns, reducing bearing wear.

ENHANCED RELIABILITY

- Advanced electronics eliminate most mechanical switches and sensors.
- Electronic water level sensor prevents problems associated with water pressure fluctuations.
- Continuous length evaporator refrigerant tubing eliminates potential refrigerant leaks.

IMPROVED EFFICIENCY

- Photoelectric eye bin control allows maximum storage in bin.
- Continuous icemaking, no hot gas cycle, no water dump.
- Lower KWH usage per 100 lbs. of ice than cubers.

NON-BRIDGING NUGGETS – EASY SERVING

- Jam-free dispensing.
- Nuggets stay separated without clustering.
- Provide maximum liquid displacement.
- Most effective ice form for carbonated beverages.

FLEXIBILITY – MORE CONVENIENCE

- Cleanable A.B.S. sink and stainless steel splash panel.
- Foam insulated 90-pound capacity storage bin.
- Mounts on counter, or on DMS31B machine stand.
- Easy front service access.
- Easy to install – utilities are connected at the backside.

ENVIRONMENTALLY RESPONSIBLE

- HFC R-404A (HP-62) refrigerant.
- Non-CFC foam insulation.

WARRANTY PROTECTION

See Dealer for details of Limited Warranty.

- 24 Month Factory Labor.
- 24 Months on all parts.
- 5 Years on Compressor.
- Directory of Certified Dealer Service.

This product qualifies for the following listings:



SCOTSMAN®
Ice Systems The World Relies On.™

Consultant/Contractor Approval

775 CORPORATE WOODS PARKWAY • VERNON HILLS, IL 60061 • (847) 215-4550
FAX (847) 913-9844

S-134

E-mail: customer.service@scotsman-ice.com

Printed in U.S.A.
3.5M 8-97

NDE750 AUTOMATIC AIR AND WATER COOLED NUGGET ICE MAKER/DISPENSER

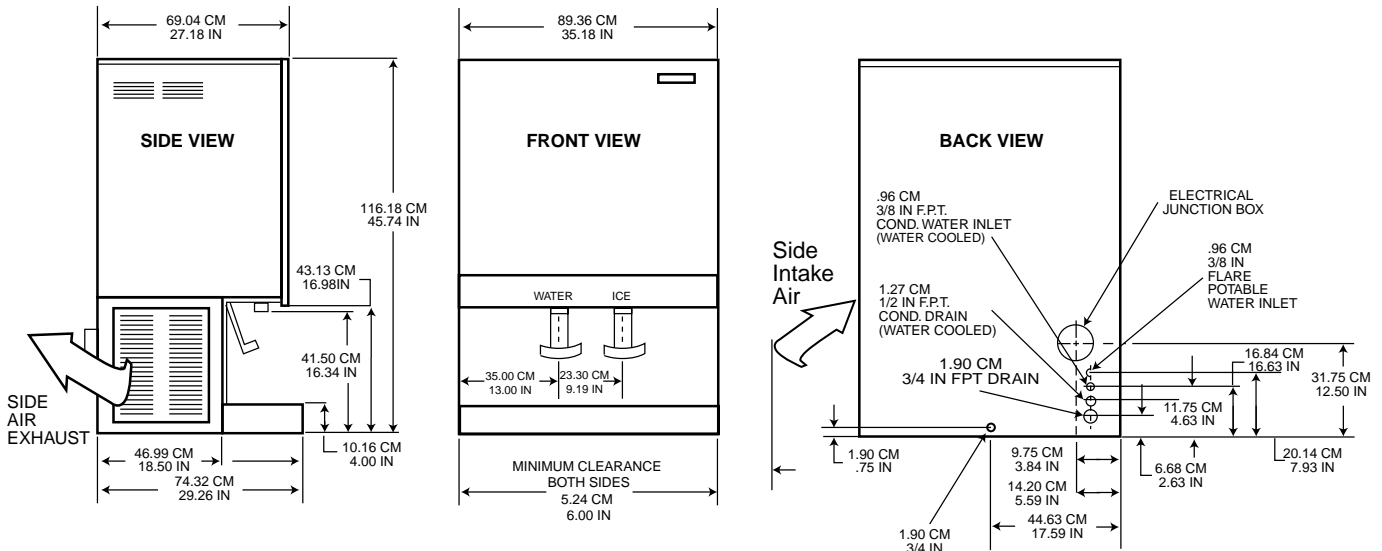

INSTALLATION NOTE: Allow 6" minimum space at sides and back for ventilation and utility connections.

All models: Dimensions: W x D x H Unit: 35³/₁₆" x 29¹/₄" x 45³/₄" Shipping Carton: 39" x 32" x 52"

Model	Cond. Unit	Ice Prod. Lbs./24 hrs.		Finish **	Ship Wt. lbs./kg.	Basic Electrical Volts/Hz/Phase	Comp HP	No. of Wires	Min. Circuit Ampacity†	Max. Fuse Size or HACR Circuit Breaker	Power KWH/100 lbs.		Water Usage* Gallons/100 lbs.		Bin Cap. lbs./kg.	
		70° Air	90° Water								90°/70°	70°/50° F	Potable 90°/70°	Condenser 70°/50° F		
NDE750AE-1A	Air	720	540	EG	350/159	115/60/1	3/4	2	18.1	25	5.6	4.0	12	12	—	90/41
NDE750AS-1A	Air	720	540	SS	355/161	115/60/1	3/4	2	18.1	25	5.6	4.0	12	12	—	90/41
NDE750WE-1A	Water	715	610	EG	350/159	115/60/1	3/4	2	16.5	20	4.3	3.7	12	12	98.2	49.0
NDE750WS-1A	Water	715	610	SS	365/166	115/60/1	3/4	2	16.5	20	4.3	3.7	12	12	98.2	49.0

* Typical ice production in lbs./kg. of ice per 24 hours at 70° air and 50° water.
 ** (EG) Grey, leathergrain embossed steel with high gloss baked enamel finish.
 (SS) Stainless steel.
 † Use this value to determine minimum wire size as per National Electric Code Standards.

OPTIONAL EQUIPMENT:

KPC750 - Portion control kit. Adds adjustable dispense rate from continuous flow down to 1 second for each actuation.

DMS31B - Machine stand for NDE750. Width: 35³/₁₆". Depth: 29³/₈". Height: 36" with 6" legs. Available in grey enamel finish or stainless steel.

ICE MAKING CAPACITY PER 24 HOURS

NDE750A AIR-COOLED WATER TEMPERATURE					NDE750W WATER-COOLED WATER TEMPERATURE				
AIR TEMPERATURE	F°	50°	70°	90°	AIR TEMPERATURE	F°	50°	70°	90°
	C°	10°	21°	32°		C°	10°	21°	32°
70°	720	630	560	lbs.	70°	715	620	520	lbs.
21°	326	286	254	kg.	21°	324	281	236	kg.
90°	600	540	480	lbs.	90°	690	610	515	lbs.
32°	272	245	218	kg.	32°	313	276	233	kg.
100°	550	485	435	lbs.	100°	680	600	560	lbs.
38°	249	220	197	kg.	38°	308	272	254	kg.

Capacities represent typical production, variances of ±5% are normal.

ICE VENDING CAPACITY

Variable Vends: From 1 oz. to continuous flow.

PEAK VENDS PER HOUR

	Bin Cap. lbs.	1-Hr. Recovery Cap.* lbs.	Number of Vends per Hour From Full Bin + Recovery			
			2 oz. Vends	4 oz. Vends	6 oz. Vends	48 oz. Vends
NDE750A	90	28	720 + 225	360 + 110	240 + 75	180 + 55
NDE750W	90	29	720 + 230	360 + 115	240 + 75	180 + 55

We reserve the right to make product improvements at any time. Specifications and design are subject to change without notice. Scotsman ice systems include a full line of ice shapes, modular and self-storing cubers, flakers, drink dispensers, bins and accessories.

IMPORTANT OPERATING REQUIREMENTS:

Machine requires voltage indicated on rating name plate. Failures caused by improper voltage are not considered factory defects.

Scotsman products are not designed for outdoor installations nor for installation where air temperatures fall below 50° F, or exceed 100° F; nor where water temperatures fall below 40° F, or exceed 100° F. Extended periods of operation at temperatures exceeding these limitations constitutes misuse under the terms of Scotsman Manufacturer's Limited Warranty, resulting in a loss of warranty coverage.

NDE SERIES NUGGET ICE MAKER/DISPENSER

Model _____ nugget icemaker manufactured by Scotsman Ice Systems. Production capacity to be _____ at 90°F air temperature and 70°F water temperature. Ice storage bin capacity to be _____. Icemaker to have a _____ (air or water) cooled condenser. Ice form to be cylindrical compressed flake ice 3/8" in diameter of random length up to 1/2". To have factory installed photoelectric eye bin level control to automatically start and stop icemaker. Evaporator and auger to be constructed of stainless steel. Exterior cabinet to be _____ (baked enamel grey leathergrain or 304 series stainless steel) finish. Icemaker to be UL, CSA, and NSF listed.

SCOTSMAN
Ice Systems The World Relies On.™

775 CORPORATE WOODS PARKWAY • VERNON HILLS, IL 60061 • (847) 215-4550

FAX (847) 913-9844

S-134

E-mail: customer.service@scotsman-ice.com

Printed in U.S.A.

3.5M 8-97