

AFE424 SERVICE PARTS

This is the parts list for the AFE424. When looking up part numbers, always check the complete model and serial numbers to be certain of ordering the correct parts.

The Air Cooled model has also been manufactured in 50 Hz.

Plastic tubing is sold by the foot, order 1 unit, and 1 foot will be shipped. Order enough to cover the length required. Lengths of tubing are listed under the description column.

Table of Contents

CABINET	Page 2
AIR COOLED REFRIGERATION	Page 3
WATER COOLED REFRIGERATION	Page 4
RESERVOIR AND TUBING	Page 5
Evaporator	Page 6
Gear Reducer 02-4399-21 or 02-4399-24 or 02-4398-21	Page 7
CONTROL BOX	Page 8
SCHEMATIC DIAGRAM	Page 9
WIRING DIAGRAM	Page 10

AFE424 SERVICE PARTS

CABINET

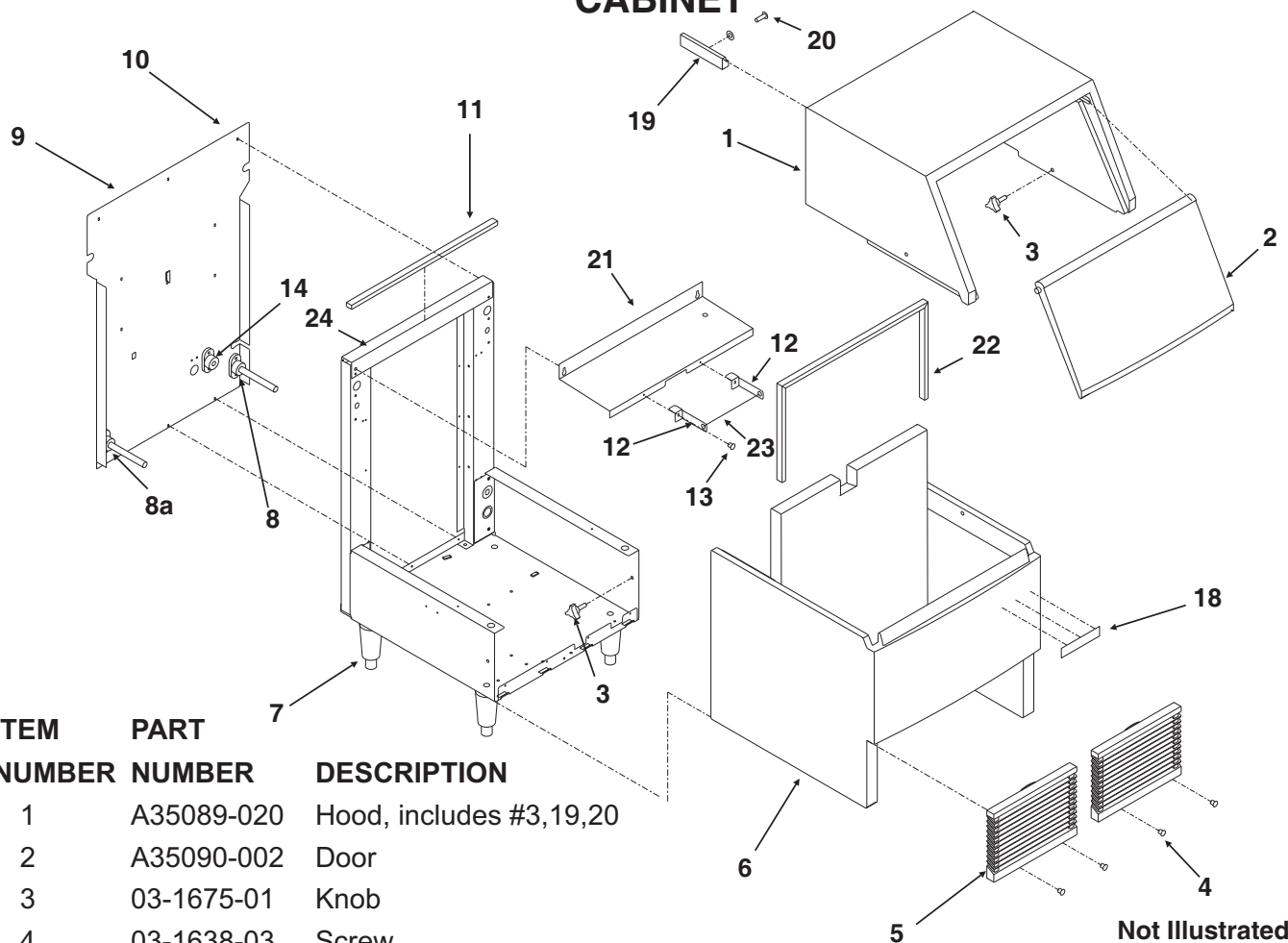

ITEM NUMBER	PART NUMBER	DESCRIPTION
1	A35089-020	Hood, includes #3,19,20
2	A35090-002	Door
3	03-1675-01	Knob
4	03-1638-03	Screw
5	02-3153-01	Grill
6	A35088-020	Bin, includes #15,16,16a, 17
7	KLP7	Leg kit
8	02-3692-21	Drain casting - bin
8a	02-3692-22	Drain casting - reservoir
9	A35248-001	Back panel
10	03-1404-29	Sheet metal screw
11	13-0609-01	Gasket, 21.75" req.
12	A35394-001	Bin control bracket
	13-0727-00	Grommet
13	03-1638-03	Screw
14	16-1154-22	Water cooled drain casting
15	02-2809-01	Drain cap
16	02-3108-01	Drain fitting
16a	03-4193-01	Washer - flat
17	16-0822-01	Adaptor
18	15-0808-01	Emblem
19	19-0629-01	Door stop

Not Illustrated:
Scoop, part number 02-3253-01

20	03-1419-09	Screw
21	A35199-001	Evaporator bracket
	13-0727-00	Grommet for cap tube
22	13-0909-01	Bin gasket 36" req.
23	13-0895-01	Plastic tube - 9" req.
24	A35452-001	Top bracket
25	13-0892-01	Spout grommet

AFE424 SERVICE PARTS

AIR COOLED REFRIGERATION

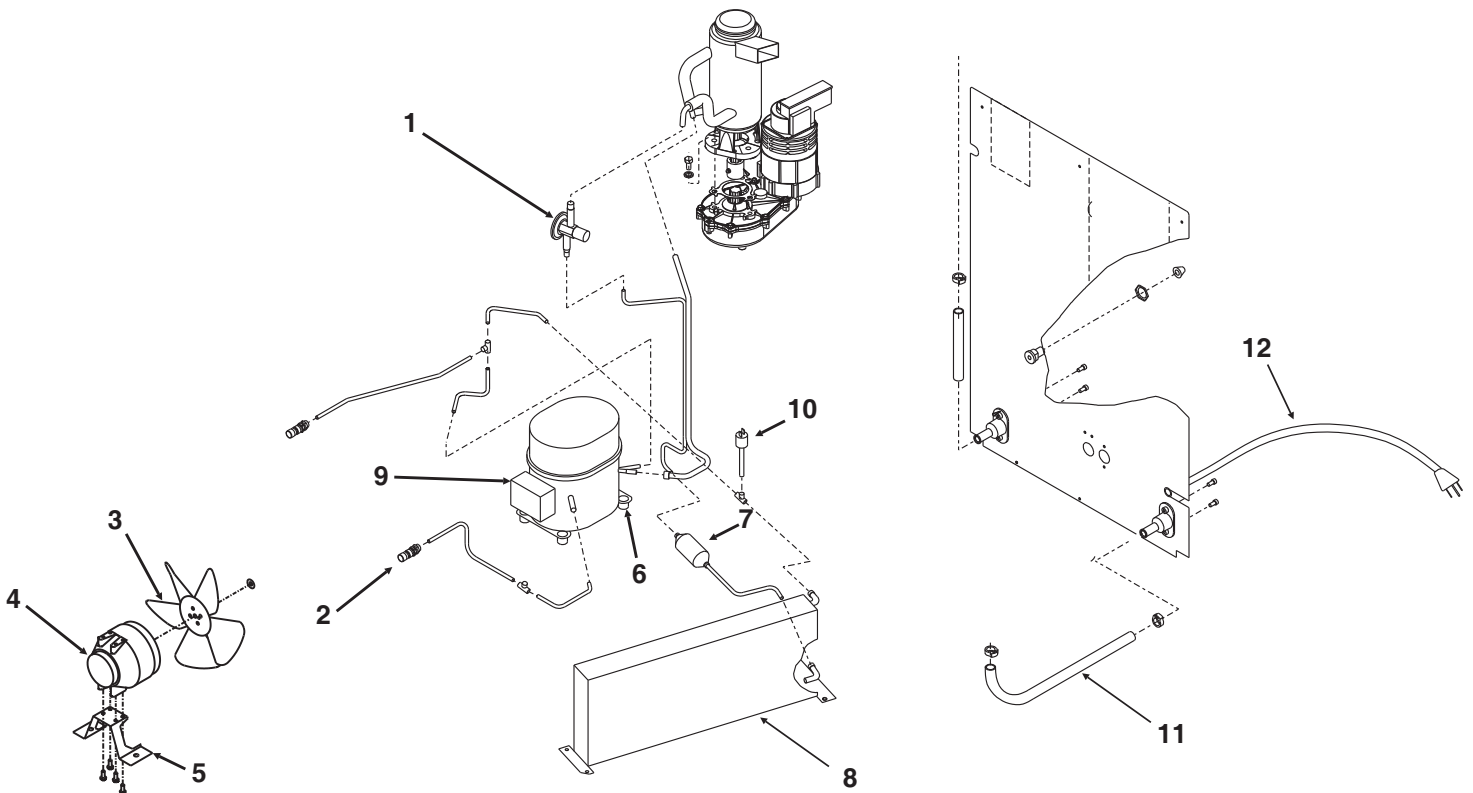

ITEM NUMBER	PART NUMBER	DESCRIPTION
1	16-1091-21	1/8 ton TXV
	19-0599-06	Insulation 6 x 9
2	16-1138-01	Access valve seat
	16-1139-01	Core
	16-1140-01	Cap
3	18-8708-01	Fan blade
4	12-1681-23	Fan motor, 115/60/1
	18-8709-03	Fan motor, 50 Hz
5	A35246-001	Fan motor bracket
6	03-1677-01	Screw
	03-1407-07	Washer
	18-2200-27	Sleeve
	18-2200-28	Grommet
7	02-3319-01	Dryer
8	18-8844-01	Air cooled condenser
	02-3193-01	Air filter (not shown)
	9	18-8918-21 60 Hz Compressor*
		60 Hz (Danfoss compressor) parts:
		18-1903-60 60 Hz relay w/overload
		18-1901-60 60 Hz start capacitor
		18-8746-26 50 Hz Compressor*
		50 Hz (Tecumseh compressor) parts:
		18-8746-25 50 Hz Start capacitor
		18-8746-24 50 Hz Relay
		18-8746-23 50 Hz Overload
		11-0501-24 Hi pressure cut out
		* Includes relay, overload, start capacitor, and drier
		11 12-1638-15 Power cord 60 Hz
		12-1638-16 Power cord for 50 Hz.
		12 13-0079-03 Tubing (21" req.)

AFE424 SERVICE PARTS

WATER COOLED REFRIGERATION

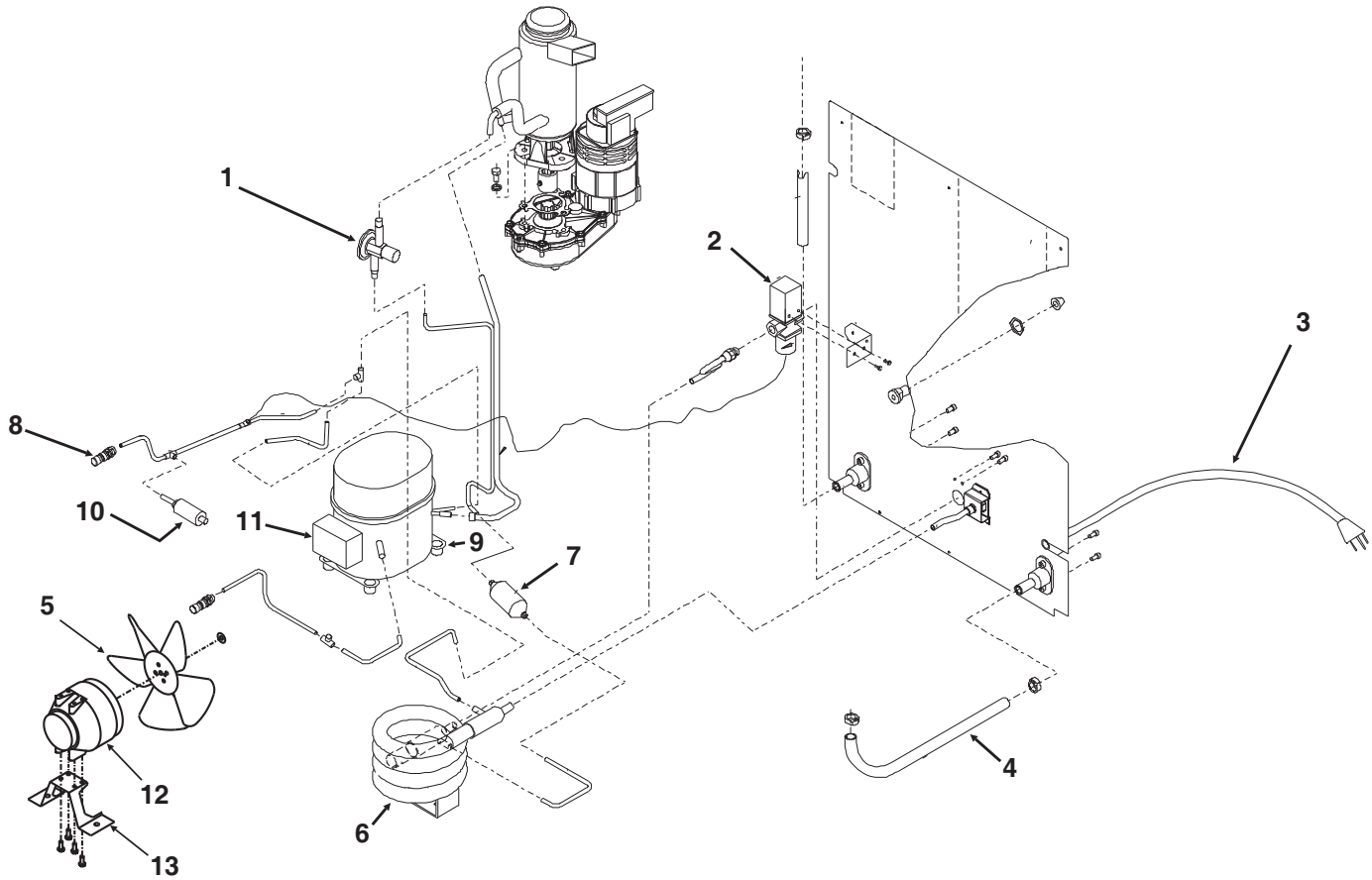

ITEM NUMBER	PART NUMBER	DESCRIPTION	ITEM NUMBER	PART NUMBER	DESCRIPTION
1	16-1091-21	TXV	10	11-0500-21	Hi press. cut out (wc)
	19-0599-06	Insulation 6 x 9	11	18-8918-21	60 Hz Compressor*
2	11-0198-02	Water reg. valve	60 Hz (Danfoss compressor) parts:		
3	12-1638-15	Power cord 60 Hz (AC also)		18-1903-60	60 Hz relay w/overload
4	13-0079-03	Tubing (21" req.)		18-1901-60	60 Hz start capacitor
5	18-8708-01	Fan blade	12	18-8752-21	Fan motor (water cooled)
6	18-8869-21	WC condenser	13	A35246-001	Fan motor bracket
7	02-3319-01	Dryer	* Includes relay, tubing, start capacitor, and drier		
8	16-1138-01	Access valve seat			
	16-1139-01	Core			
	16-1140-01	Cap			
9	03-1677-01	Screw			
	03-1407-07	Washer			
	18-2200-27	Sleeve			
	18-2200-28	Grommet			

AFE424 SERVICE PARTS

RESERVOIR AND TUBING

ITEM NUMBER	PART NUMBER	DESCRIPTION
1	13-0895-01	Poly Tubing
2	16-1081-01	Inlet elbow, used with male connector and plastic tubing
3	16-0871-01	Brass insert
4	16-1040-01	Inlet T
5	02-3268-01	Clip
6	11-0296-00	Water pressure sw.
6a	16-1046-01	Plastic tube connector to switch
7	13-0859-01	Rubber plug
8	13-0674-09	Drain tube, 12" req.
9	02-2814-07	Hose clamp
10	13-0674-09	Outlet tube, 4" req.
11	16-0670-02	Tee
12	13-0674-09	Evap. inlet tube, 6" req.
13	13-0079-03	Overflow tube, 32" req.
14	02-2217-01	Reservoir & valve
15	02-2217-02	Float valve
16	16-0835-01	Male flare connector, used with item 17

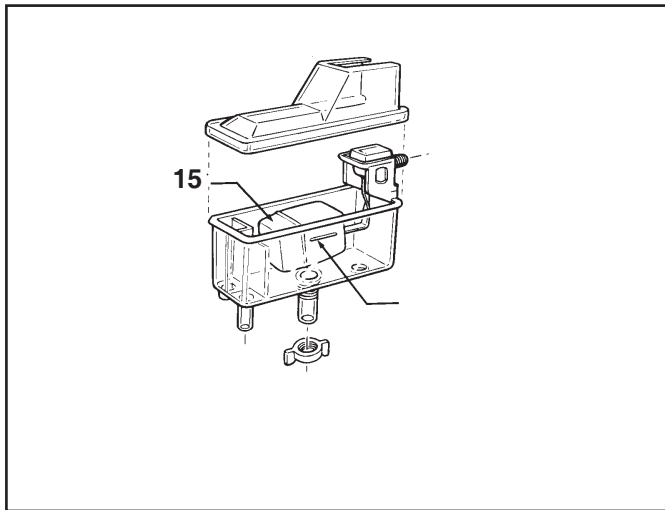
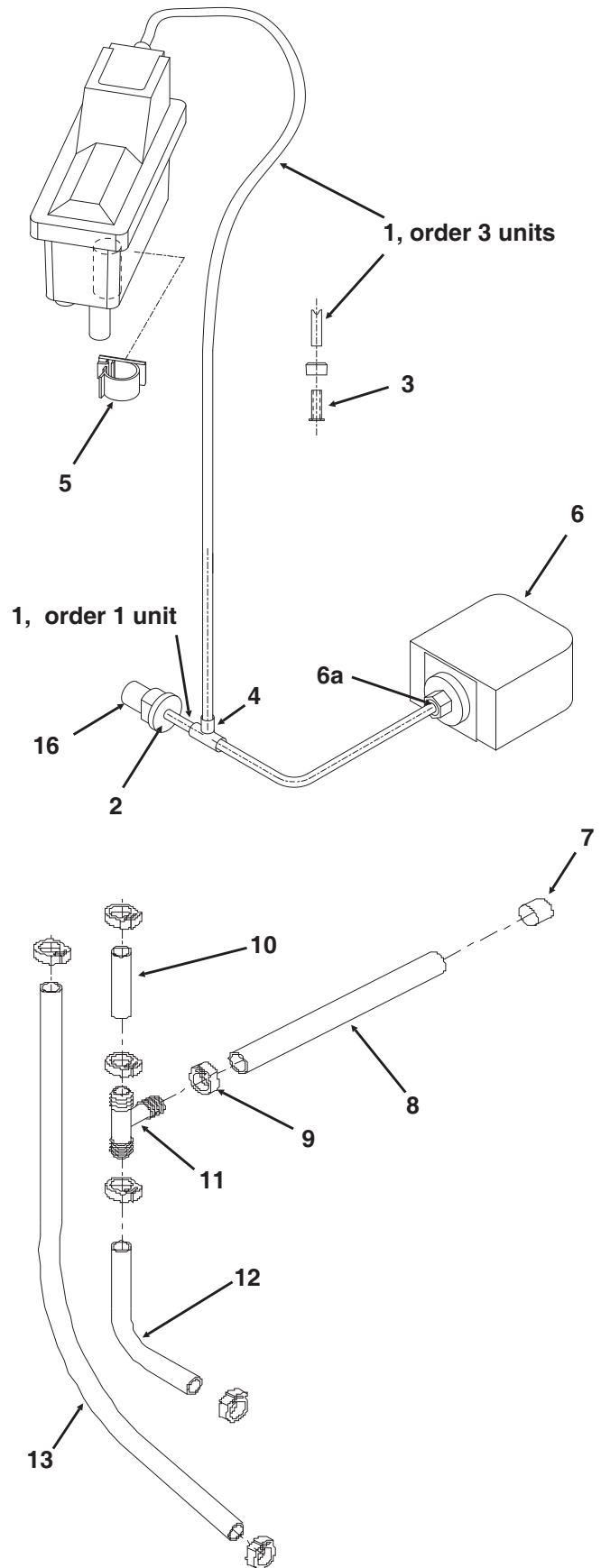

AFE424 SERVICE PARTS

Evaporator and Related Parts

ITEM NUMBER	PART NUMBER	DESCRIPTION
1	02-4404-02	Threaded cap
2	03-0758-00	Screw
3	02-4535-01	Top bearing, w/thrust washer
4	02-4575-21	Breaker kit, includes items 1, 3, 4a, 4b,, 7 & 7a
4a	13-0617-16	O-Ring (inside)
4b	13-0617-37	O-Ring, outside of breaker
5	02-4574-01	Auger
6	02-3449-20	Evaporator*
7	03-1417-07	Washer
7a	03-1403-46	Screw
8	02-4599-01	Water Seal
9	02-0417-20	Lower Bearing
10	03-1505-00	Gasket
11	08-0595-01	Adapter
12	03-1405-38	Cap Screw (3)
13	03-1420-01	Cap screw
14	03-1410-04	Washer (3)
15	A29915-002	Spline Coupling
16	02-4578-01	Auger and bearing kit

Includes items 1, 2, 4, 4a, 4b, 5, 7, 7a, 8, and 9

17 19-0662-02 Top bearing grease, 13 oz tube

Note: Use about 1 oz per bearing. Lightly coat bearing surfaces, thoroughly grease thrust portion of bearing (horizontal needles).

* Not available as an assembly.

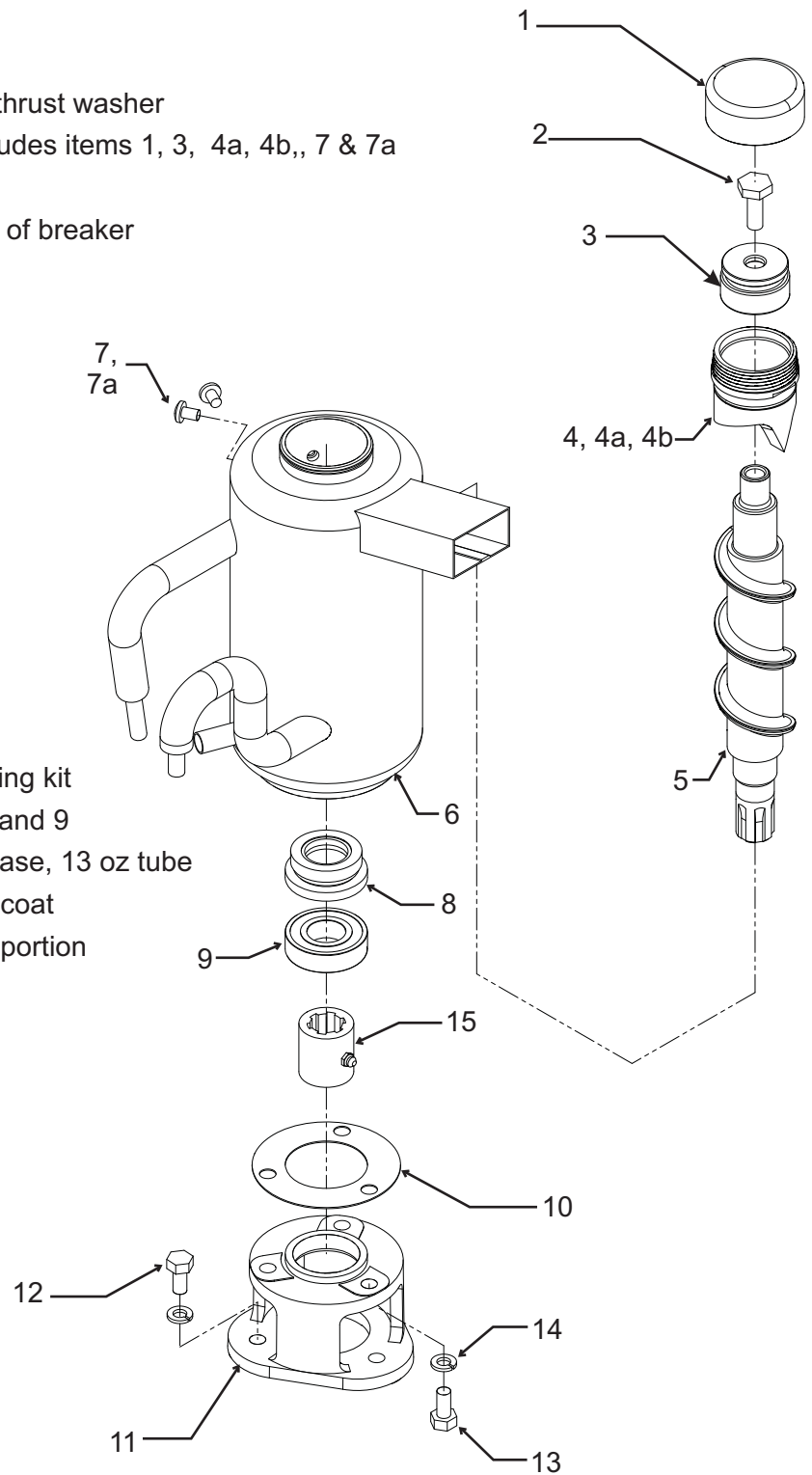

AFE424 SERVICE PARTS

Gear Reducer 02-4399-21 or 02-4399-24 or 02-4398-21

ITEM NUMBER	PART NUMBER	DESCRIPTION
1.	12-2059-01	Switch
2.	A27494-001	Centrifugal Sw. Kit
3.	03-1403-77	Screw
4.	A30579-001	Shaft and Actuator
5.	part of item 2	
6.	03-1408-36	Washer
7.	02-1503-00	Grease seal
8.	13-0947-01	Gasket
9.	03-1408-39	Washer
10.	03-1408-40	Washer shim
11.	02-2439-01	Second gear and third pinion
12.	03-1408-41	Washer
13.	03-1408-38	Washer
14.	02-2438-01	First gear and second pinion
15.	02-3969-20	Grease seal
16.	02-1501-00	Bearing
17.	03-1408-08	Washer
18.	A37707-021	60 Hz motor kit*
19.	A28168-001	Fan
20.	A38487-001	Motor Housing with bearing
21.	A32379-027	Oil
22.	02-4399-21	Complete 60 Hz Gear Motor Assembly with motor
	02-4399-24	Complete 50 Hz Gear Motor Assembly with motor
	02-4398-21	Gear reducer kit, no motor
23.	A24295-001	Spacer
24.	03-1408-02	Washer
25.	03-1405-45	Screw
26.	13-0639-00	Grommet

* motor kit includes items 16, 17, 19, 20

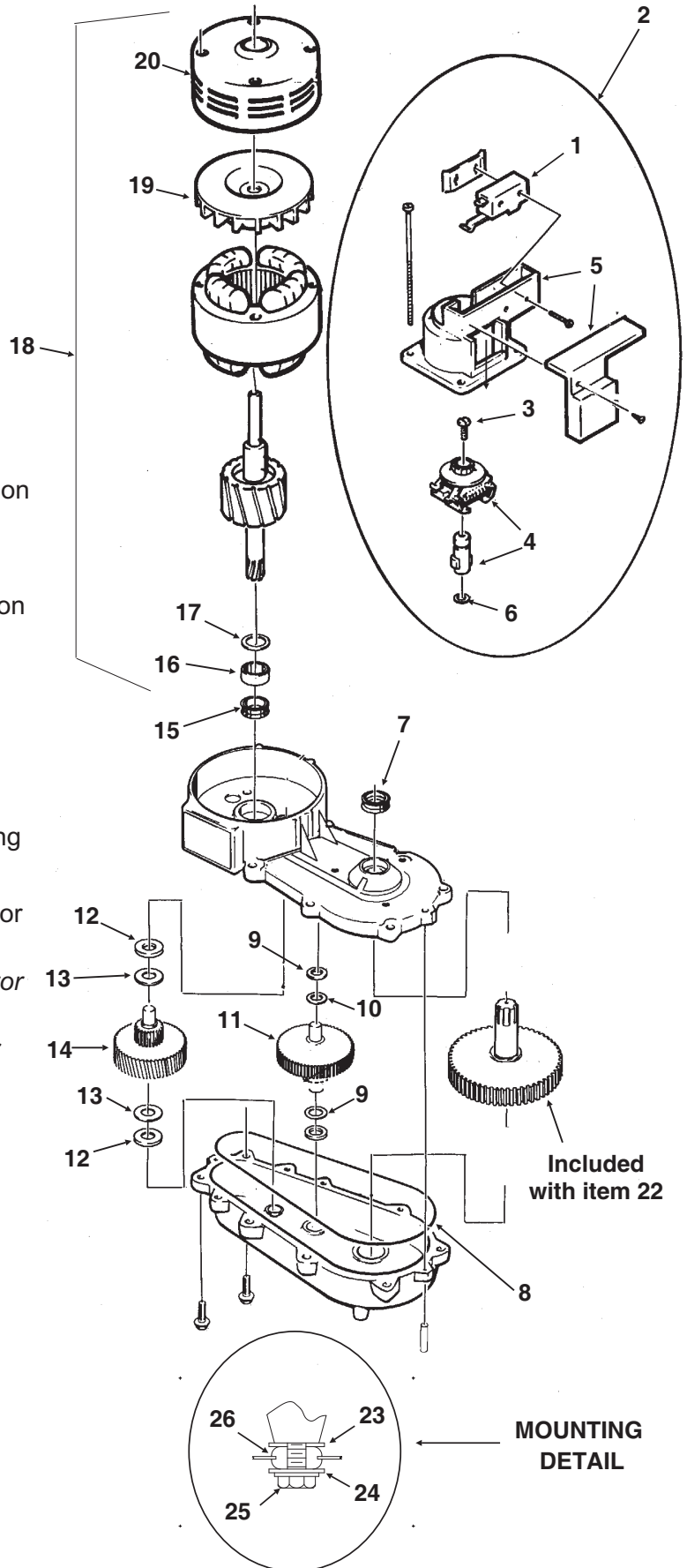

AFE424 SERVICE PARTS

CONTROL BOX

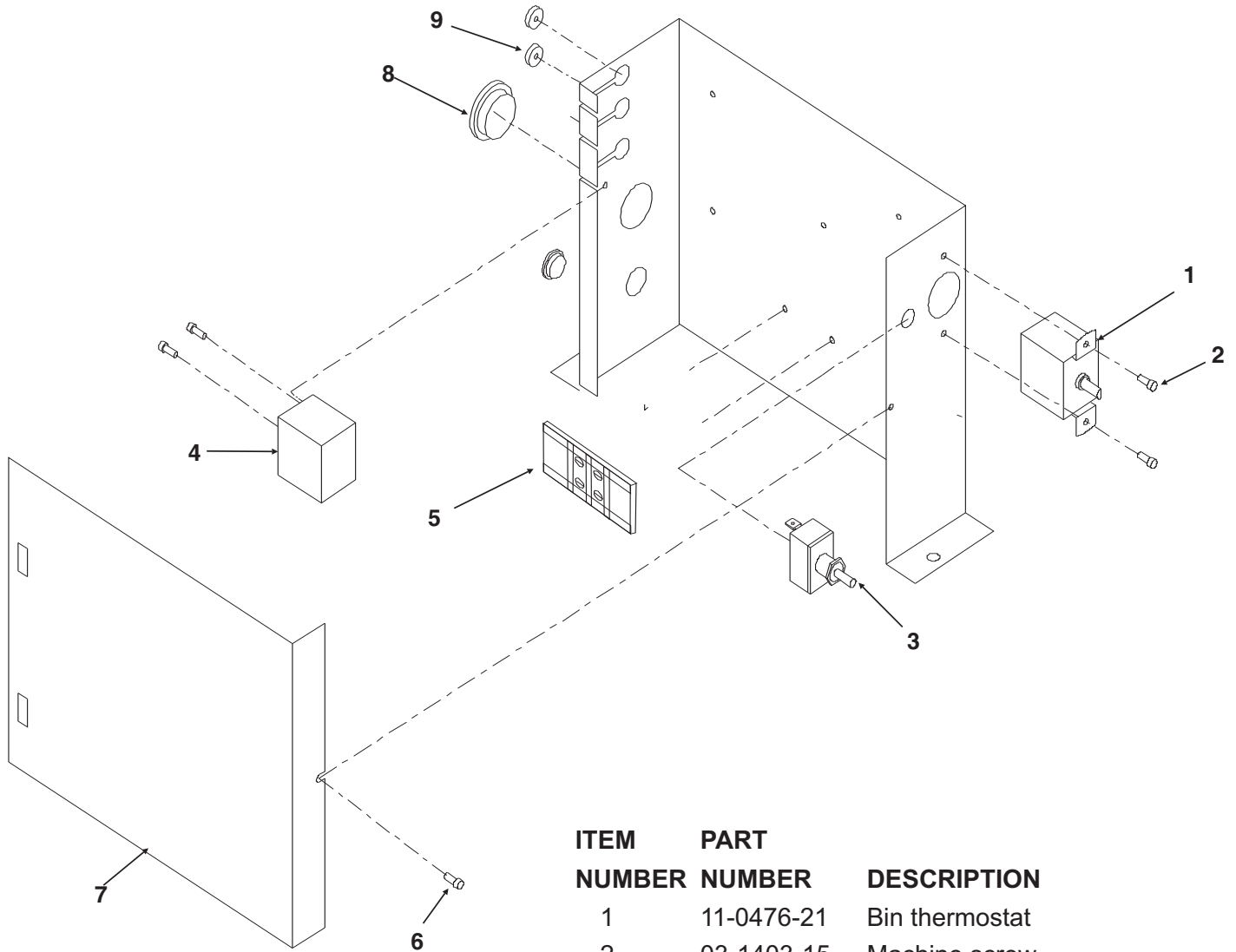

ITEM NUMBER	PART NUMBER	DESCRIPTION
1	11-0476-21	Bin thermostat
2	03-1403-15	Machine screw
3	12-0426-01	Toggle switch, spst
4	11-0402-21	Auger delay control
5	12-0813-04	Terminal block
6	03-1404-29	Sheet metal screw
7	A35273-001	Control box cover
8	12-1213-11	Snap bushing
9	13-0727-00	Grommet

AFE424 SERVICE PARTS SCHEMATIC DIAGRAM

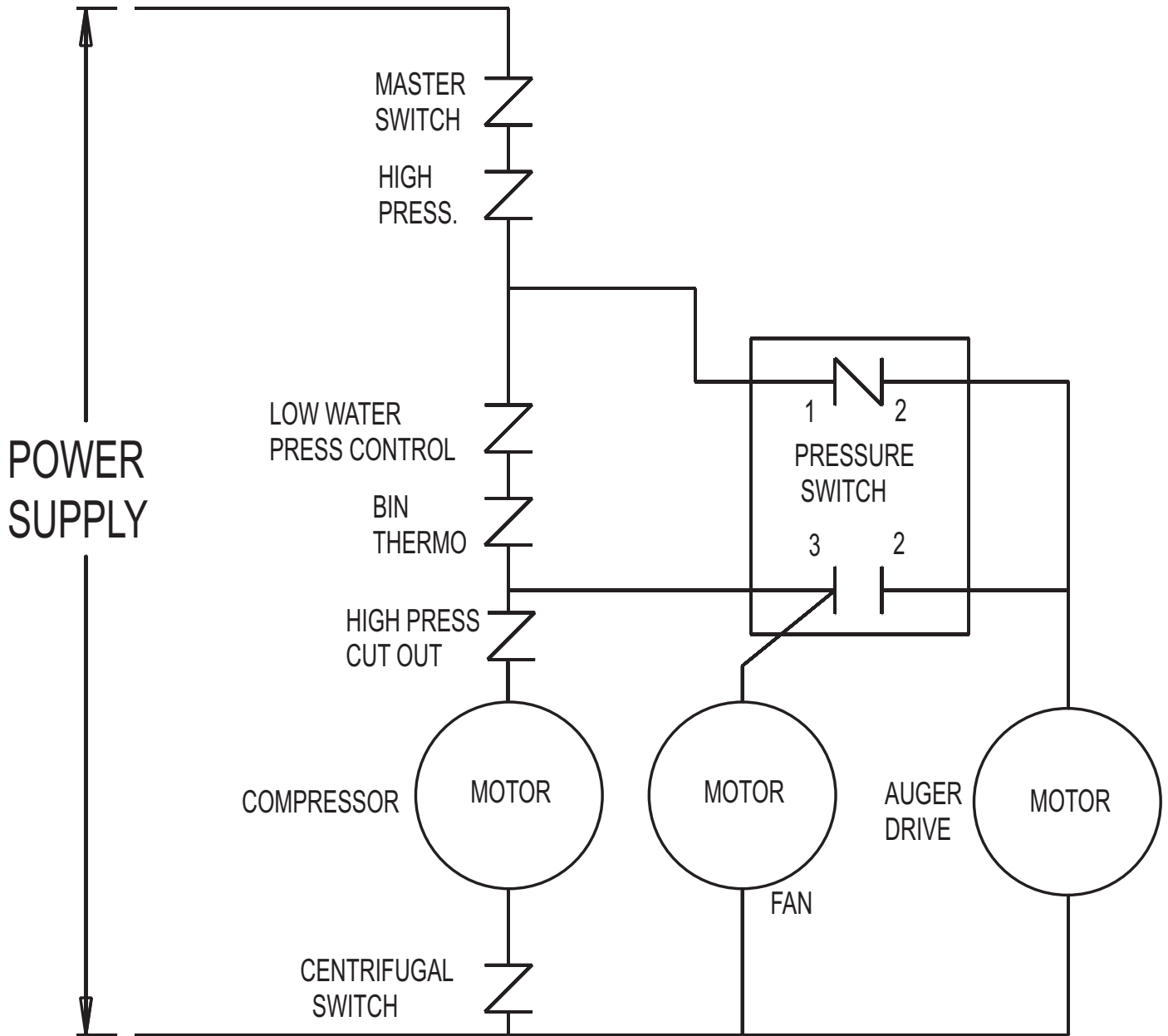

AFE424 SERVICE PARTS WIRING DIAGRAM

17-3094-01

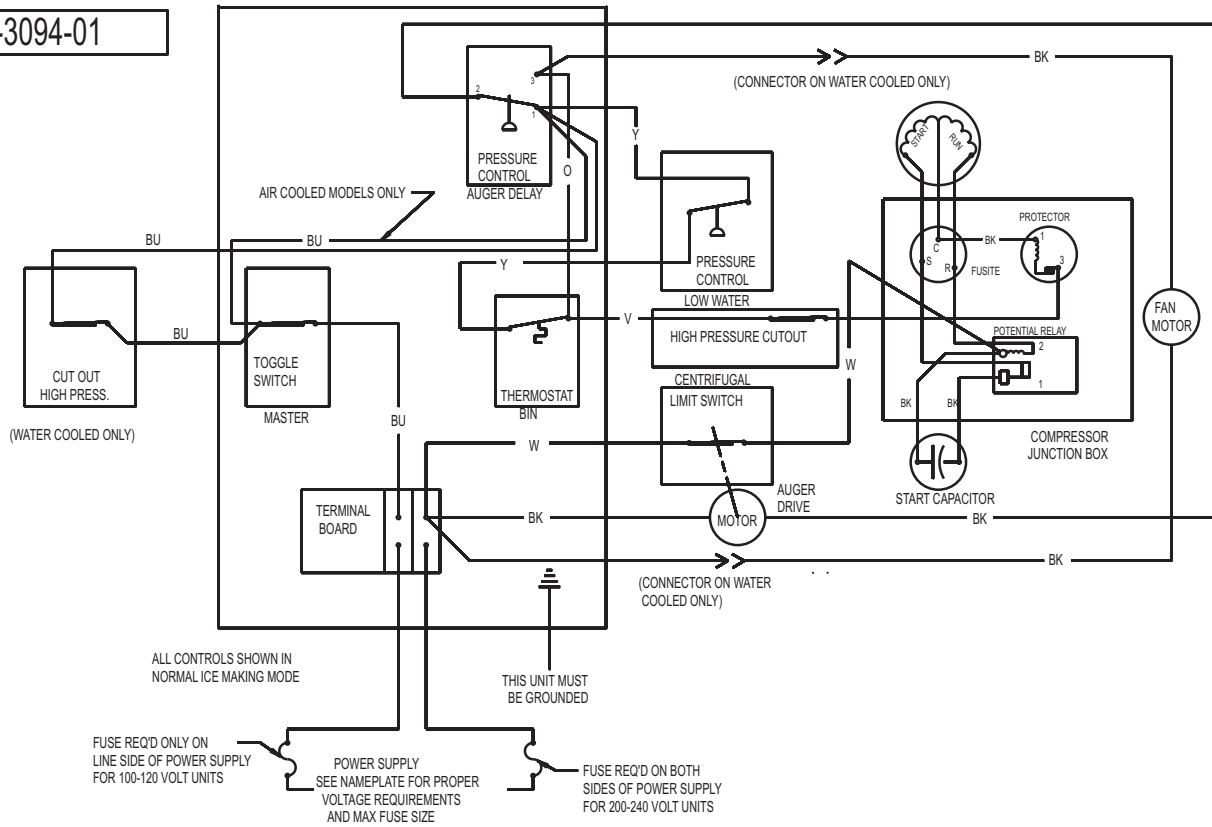

**ALL CONTROLS SHOWN IN NORMAL ICE MAKING MODE
THIS UNIT MUST BE GROUNDED**