

FM800 SERVICE PARTS

This parts list contains the service parts and wiring diagrams for this model. Check the model number in question to be sure that it is applicable to this parts list.

This model ice maker has been manufactured in two voltages. When looking for electrical components, check to be sure that the voltage of the part matches the voltage of the machine that needs the part.

TABLE OF CONTENTS

Cabinet	2
Air Cooled Refrigeration.....	3
Water Cooled Refrigeration.....	4
Water System.....	5
Gearmotor.....	6
Evaporator	7
Control Box.....	8
Wiring Diagrams.....	9

FM800 SERVICE PARTS

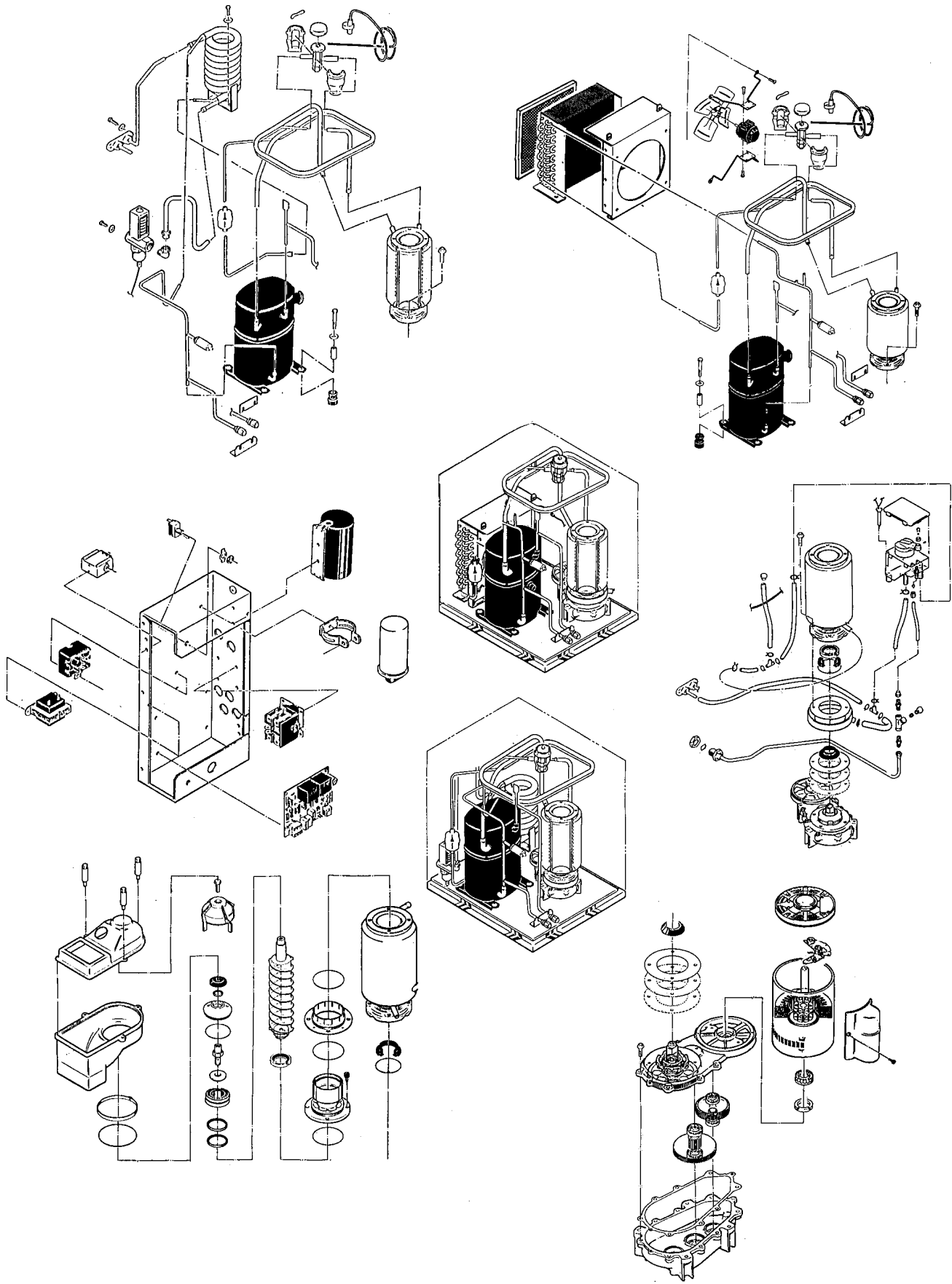

FM800 SERVICE PARTS Cabinet Assembly

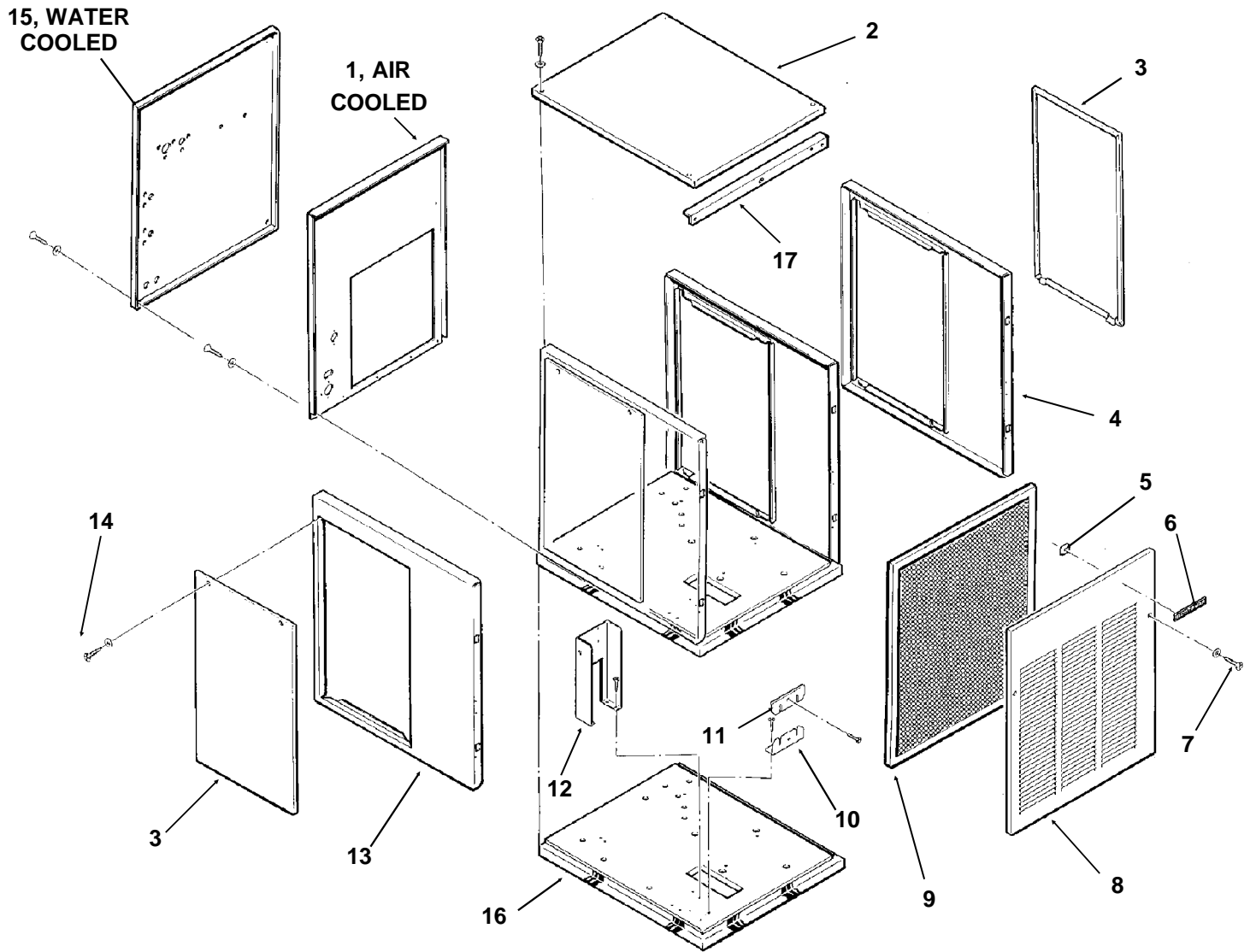

ITEM NUMBER	PART NUMBER	DESCRIPTION	ITEM NUMBER	PART NUMBER	DESCRIPTION
1	A34544-001	Back Panel, Air Cooled	9	02-2976-01	Filter Assembly
2	A33256-001	Top Panel, Painted	10	A31462-001	Tube Bracket
	A33256-002	Top Panel, S.S.	11	A31461-001	Tube Bracket
3	A34038-001	Service Panel, Painted	12	A34039-001	Control Box Support
	A34038-002	Service Panel, S.S.	13	A32435-001	Left Side Panel, Painted
4	A33292-001	Right Side Panel, Painted		A32435-002	Left Side Panel, S.S.
	A33292-002	Right Side Panel, S.S.	14	03-1404-12	Screw
5	03-0271-00	Speed Clip	15	A33252-001	Rear Panel, Water Cooled Painted Only
6	15-0711-01	Emblem			
7	03-1419-08	Screw	16.	A34042-001	Base
8	A33255-001	Front Panel, Painted	17	A34348-001	Front Brace, Air Cooled
	A33255-002	Front Panel, S.S.			

FM800 SERVICE PARTS

Air Cooled Refrigeration

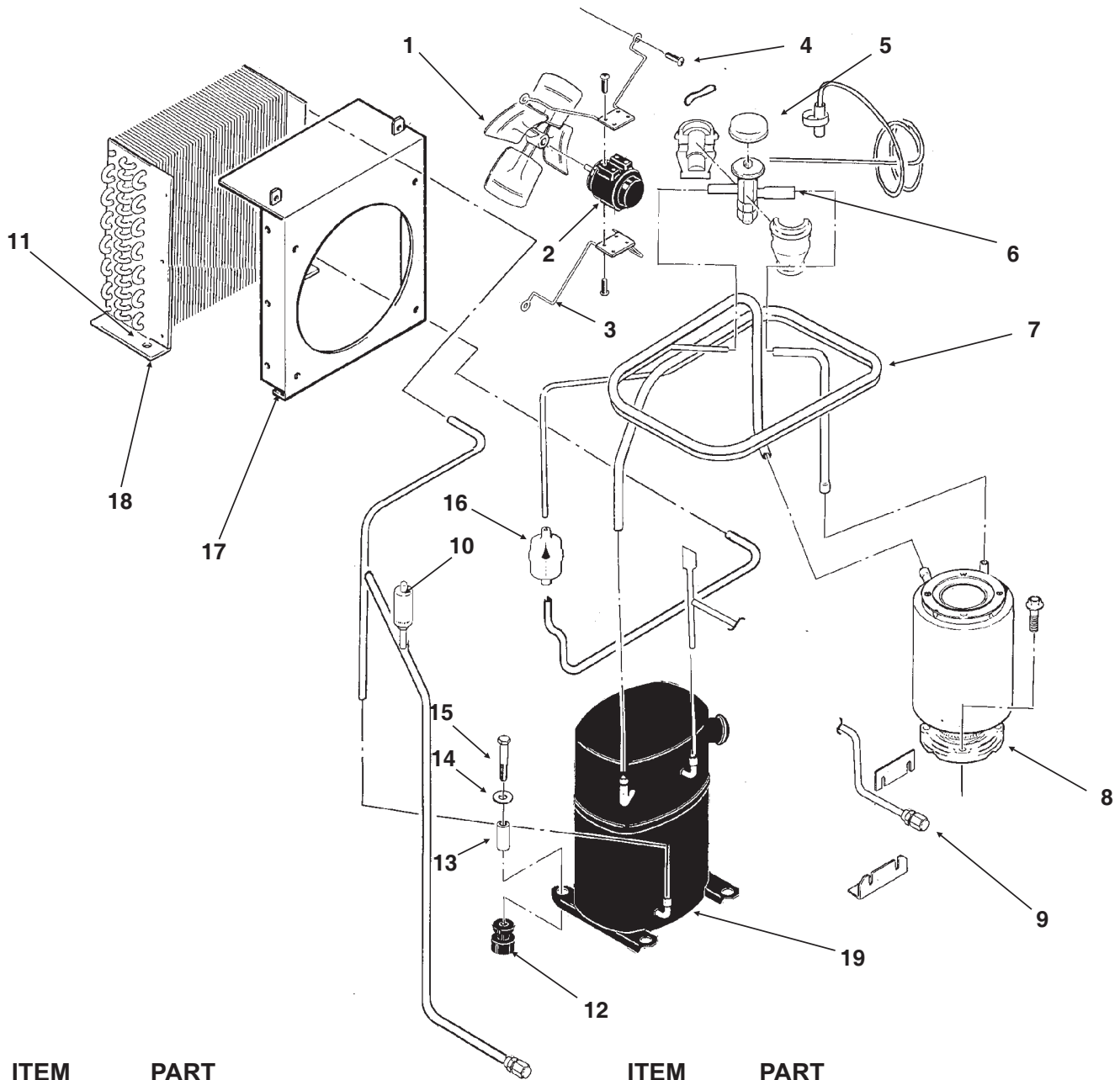

ITEM NUMBER	PART NUMBER	DESCRIPTION	ITEM NUMBER	PART NUMBER	DESCRIPTION
1	18-3815-01	Fan Blade	11	03-1645-01	Screw
2	12-1576-02	Fan Motor 208-230 v	12	18-2200-28	Grommet
	12-1576-01	Fan Motor 115 v	13	18-2200-27	Sleeve
3	02-2378-01	Fan Bracket	14	03-1407-07	Washer
4	03-1531-01	Screw	15	03-1405-20	Cap Screw
5	A32961-020	Insulation Kit (3 piece)	16	02-3319-02	Dryer
6	16-0780-01	Thermo Expansion Valve	17	A34618-001	Fan Shroud
7	A34536-001	Suction Line		A34617-001	Fan shroud cover
8	A33194-020	Evaporator	18	18-7800-01	Condenser
9	16-0560-00	Valve Core	19	18-6100-02	Compressor 208-230 v
	16-0563-00	Valve Cap		18-6100-51	Overload for 208-230 v
10	11-0446-22	Hi Pressure Cut Out		18-6100-01	Compressor 115 v
				18-6100-50	Overload for 115 v

FM800 SERVICE PARTS

Water Cooled Refrigeration

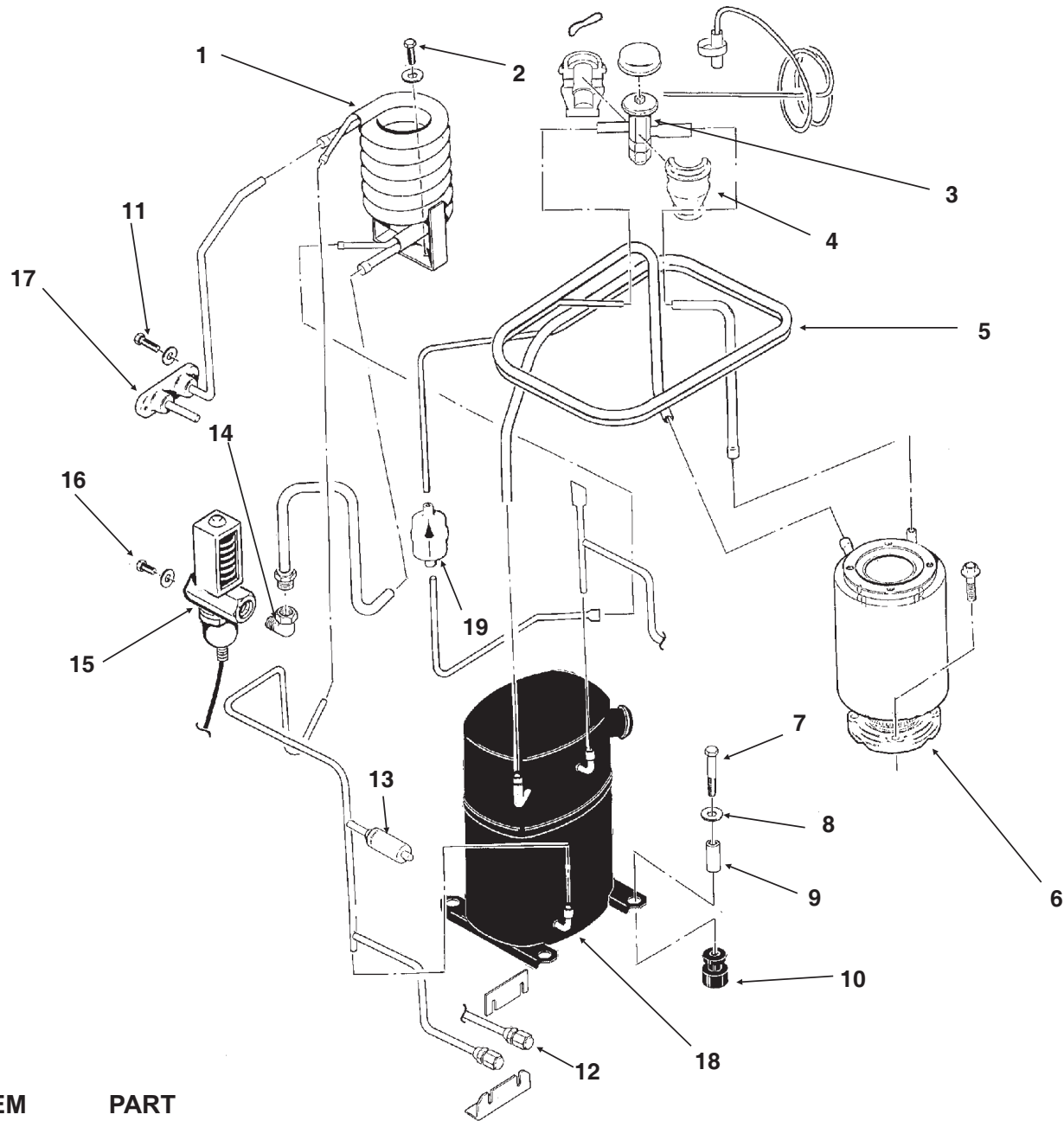

ITEM NUMBER	PART NUMBER	DESCRIPTION
1	18-3306-25	Condenser
2	03-1645-01	Screw
3	16-0780-01	Thermo Expansion Valve
4	A32961-020	Insulation Kit (3 piece)
5	A34536-001	Suction Line
6	A33194-020	Evaporator
7	03-1405-20	Cap Screw
8	03-1407-07	Washer
9	18-2200-27	Sleeve
10	18-2200-28	Grommet
11	03-1645-01	Screw
12	16-0560-00	Valve Core
13	11-0446-22	Hi Pressure Cut Out
14	16-0401-02	Elbow
15	11-0424-01	Water Reg. Valve
16	03-1403-14	Screw
17	A34543-001	Drain Assembly
18	18-6100-01	Compressor 115/60/1
	18-6100-50	Overload 115v
	18-6200-02	Compressor 208-230/60/1
	18-6100-51	Overload 208-220v
19	02-3319-02	Dryer

FM800 SERVICE PARTS

Water System

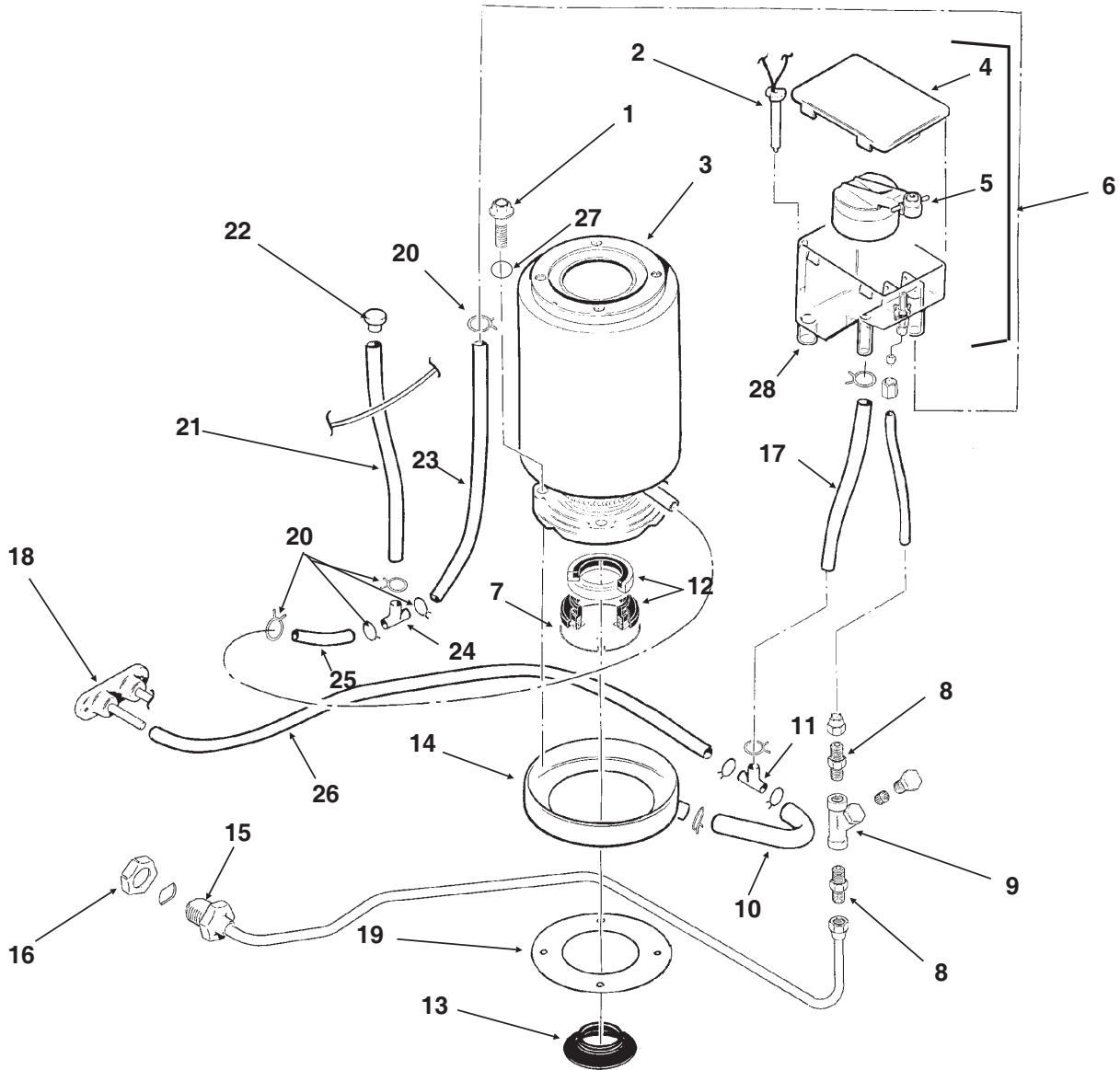

ITEM NUMBER	PART NUMBER	DESCRIPTION	ITEM NUMBER	PART NUMBER	DESCRIPTION
1	03-1420-03	Cap Screw	14	A32050-001	Drip Pan
2	A33101-021	Water Level Sensor	15	A27318-001	Water Inlet Fitting
3	A33194-020	Evaporator	16	03-1394-01	Pal Nut
4	02-2936-01	Res. Cover	17	13-0079-03	Res. Overflow, 8" req.
5	A32907-001	Float Assembly with pin housing seal, rubber seat, insert & float	18	A32282-004	Drain Casting, air cooled
6	A32918-001	Rubber seat	19	13-0704-00	Gasket
6	A32929-020	Reservoir Assy Complete	20	02-2814-08	Clamps
7	A32777-001	Retaining Ring for seal	21	13-0674-06	Evap. Drain, 14" req.
8	16-0791-01	Half Union	22	A33205-001	Plug
9	16-0162-00	Strainer	23	13-0674-06	Evap. Inlet Tube, 5" req.
10	13-0079-03	Tube, 3.2" req.	24	16-0670-01	Tee
11	16-0670-02	Tee	25	A33203-001	Tube, Preformed
12	02-0929-23	Water Seal	26	13-0079-03	Drain Tube, 24" req.
13	13-0868-01	Water Shed	27	03-1417-13	Lockwasher
			28	13-0230-00	Rubber cap

FM800 SERVICE PARTS

Gearmotor

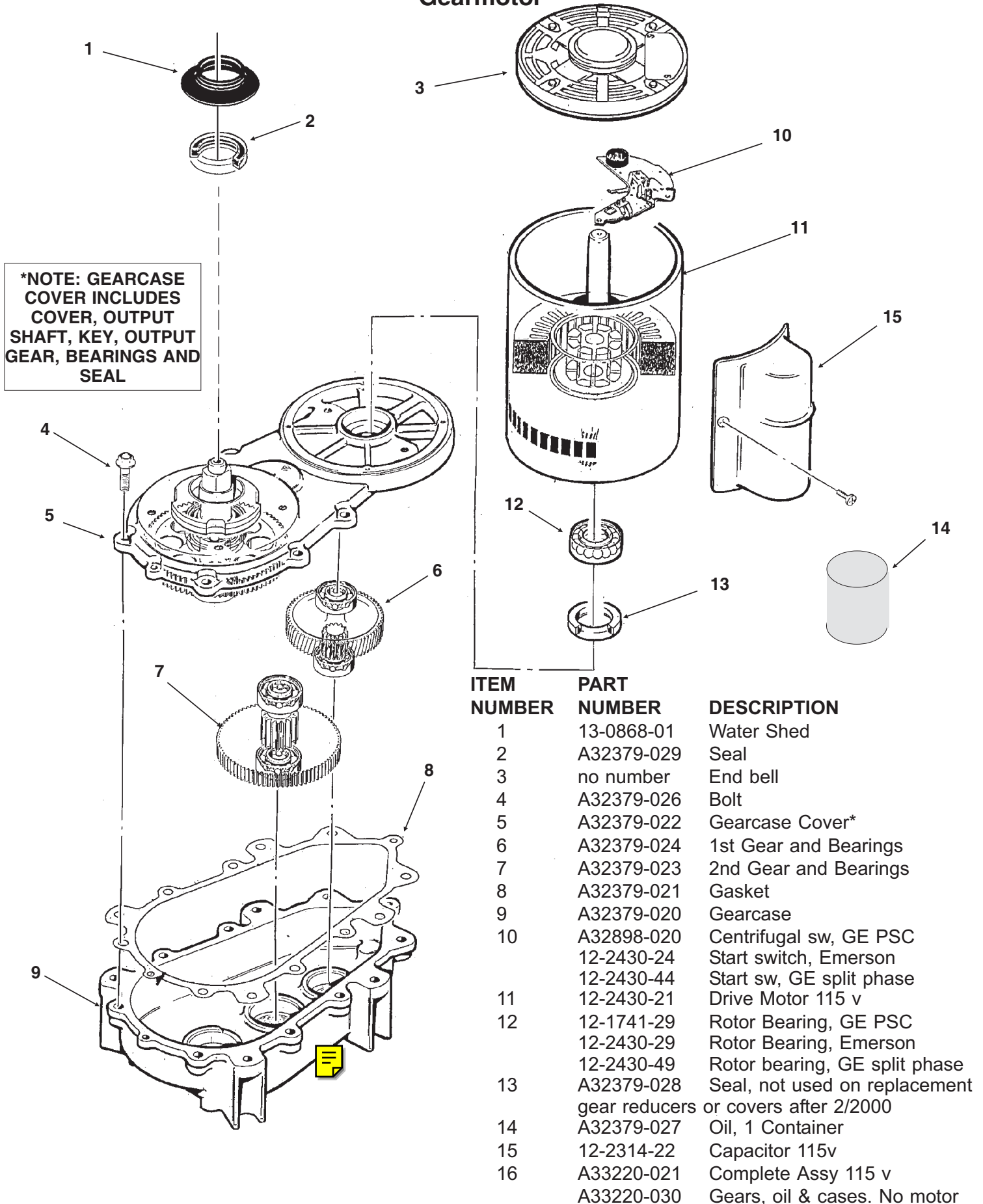

*NOTE: GEARCASE COVER INCLUDES COVER, OUTPUT SHAFT, KEY, OUTPUT GEAR, BEARINGS AND SEAL

ITEM NUMBER	PART NUMBER	DESCRIPTION
1	13-0868-01	Water Shed
2	A32379-029	Seal
3	no number	End bell
4	A32379-026	Bolt
5	A32379-022	Gearcase Cover*
6	A32379-024	1st Gear and Bearings
7	A32379-023	2nd Gear and Bearings
8	A32379-021	Gasket
9	A32379-020	Gearcase
10	A32898-020	Centrifugal sw, GE PSC
	12-2430-24	Start switch, Emerson
	12-2430-44	Start sw, GE split phase
11	12-2430-21	Drive Motor 115 v
12	12-1741-29	Rotor Bearing, GE PSC
	12-2430-29	Rotor Bearing, Emerson
	12-2430-49	Rotor bearing, GE split phase
13	A32379-028	Seal, not used on replacement gear reducers or covers after 2/2000
14	A32379-027	Oil, 1 Container
15	12-2314-22	Capacitor 115v
16	A33220-021	Complete Assy 115 v
	A33220-030	Gears, oil & cases. No motor

FM800 SERVICE PARTS

Evaporator

Bail Clamp, pn
A34969-001 use began
Jan. 91.

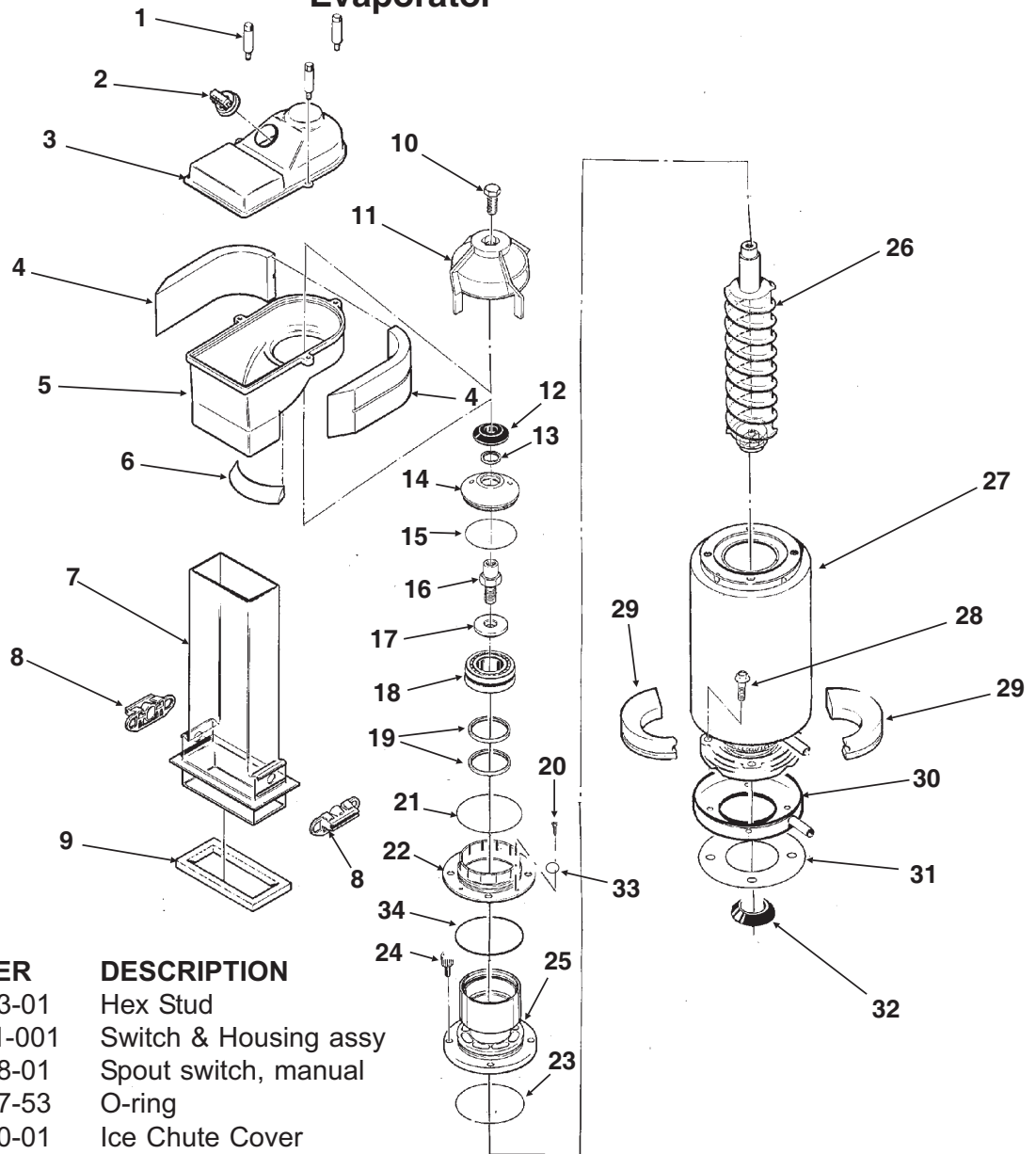

ITEM NUMBER	PART NUMBER	DESCRIPTION
1.	02-2933-01	Hex Stud
2.	A32891-001	Switch & Housing assy
	12-2398-01	Spout switch, manual
	13-0617-53	O-ring
3.	02-2930-01	Ice Chute Cover
4.	A32963-001	Insulation Top (half)
5.	02-2926-01	Ice Chute Body
6.	A33102-001	Insulation Collar Inside
	A35419-020	Strap kit
7.	02-2929-03	Ice Chute Lower
8.	A37708-021	Bin Controls Assy. (set)
9.	A32930-001	Chute Gasket
10.	03-1405-52	Hex Cap Screw
11.	02-3001-01	Ice Sweep
12.	13-0871-01	Water Shed
13.	02-2978-01	Lip Seal
14.	02-3128-20	Breaker Cover
15.	13-0617-54	O-Ring
16.	08-0660-01	Auger Stud
17.	no number	Thrust Washer part of #16
18.	A34559-020	Bearing
19.	02-2977-01	Lip Seal
20.	03-1403-27	Screw
	21.	13-0617-52 O-Ring
	22.	02-2916-01 Slotted Collar
	23.	13-0617-45 O-Ring
	24.	03-1544-08 Soc. Head Screw
	25.	A34505-020 Breaker (Divider) (includes 13, 14, 15, 18 & 19)
	26.	A38071-021 Auger
	27.	A33194-020 Evaporator
	28.	03-1405-41 Cap Screw
	29.	A32902-001 Insulation Bot. (half)
		A32902-002 Insulation (half)
	30.	A37705-021 Drip Pan
	31.	13-0704-00 Drip Pan Gasket
	32.	13-0868-01 Water Shed
	33.	03-1408-36 Washer
	34.	13-0617-49 O-Ring

FM800 SERVICE PARTS Control Box

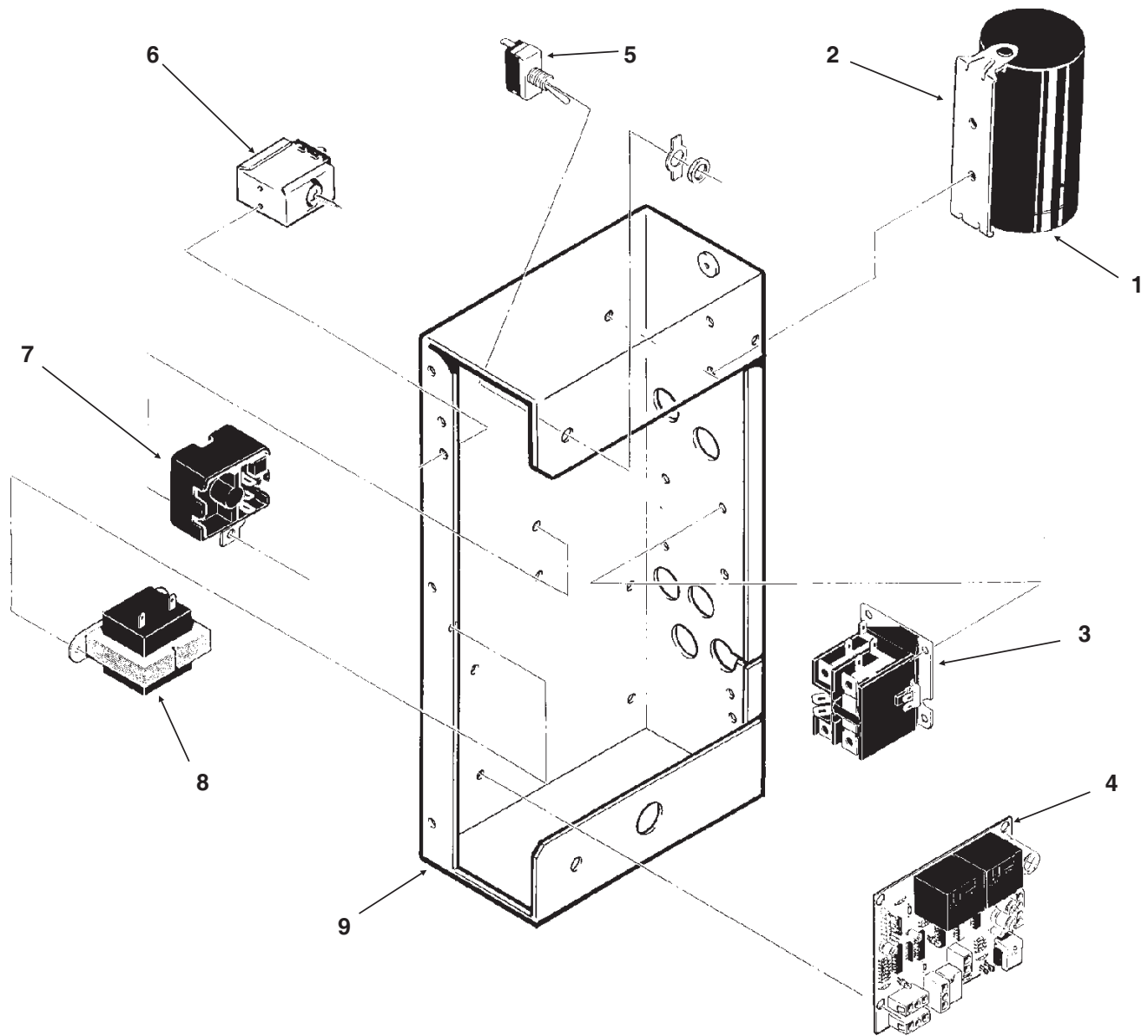

ITEM NUMBER	PART NUMBER	DESCRIPTION	ITEM NUMBER	PART NUMBER	DESCRIPTION
1	18-1901-40	Start Cap 208-230 v	7	18-1903-33	Potential Relay 208-230 volt
	18-1901-42	Start Capacitor 115 v		18-1903-44	Potential Relay 115 volt
	18-2200-38	Start Capacitor Cap.		12-2285-21	Transformer 115v
2.	18-2200-39	Start Capacitor Bracket		12-2285-22	Transformer 220v
	03-1638-04	Screw	9	no number	Control Box
	03-1417-15	Lockwasher		NOT ILLUSTRATED	
3.	12-2469-02	Contactor 208-230 v	10.	12-2337-02	3 Pin Plug Assy (Safety Circuit to Circuit Board)
	12-2469-03	Contactor 115 v	11.	12-2340-01	4 Pin Plug Assy (Transformer to Circuit Board)
4	A37750-022	Circuit Board	12.	A34055-001	Control Box Cover
5.	12-0426-01	Master Switch			
6.	11-0447-20	Low Pressure Control			

FM800 SERVICE PARTS Wiring Diagram

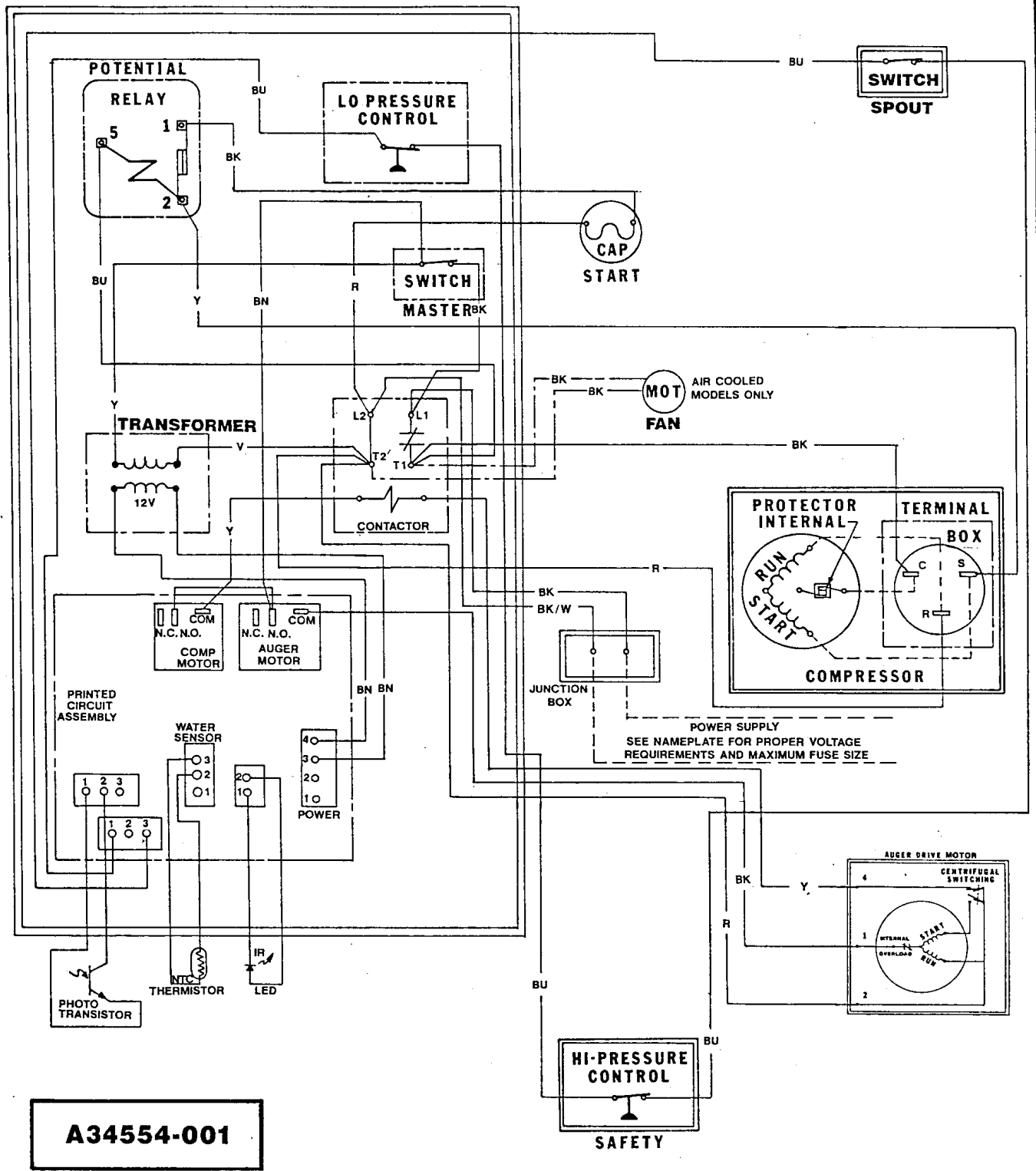

A34554-001

FM800 SERVICE PARTS

Schematic Diagram

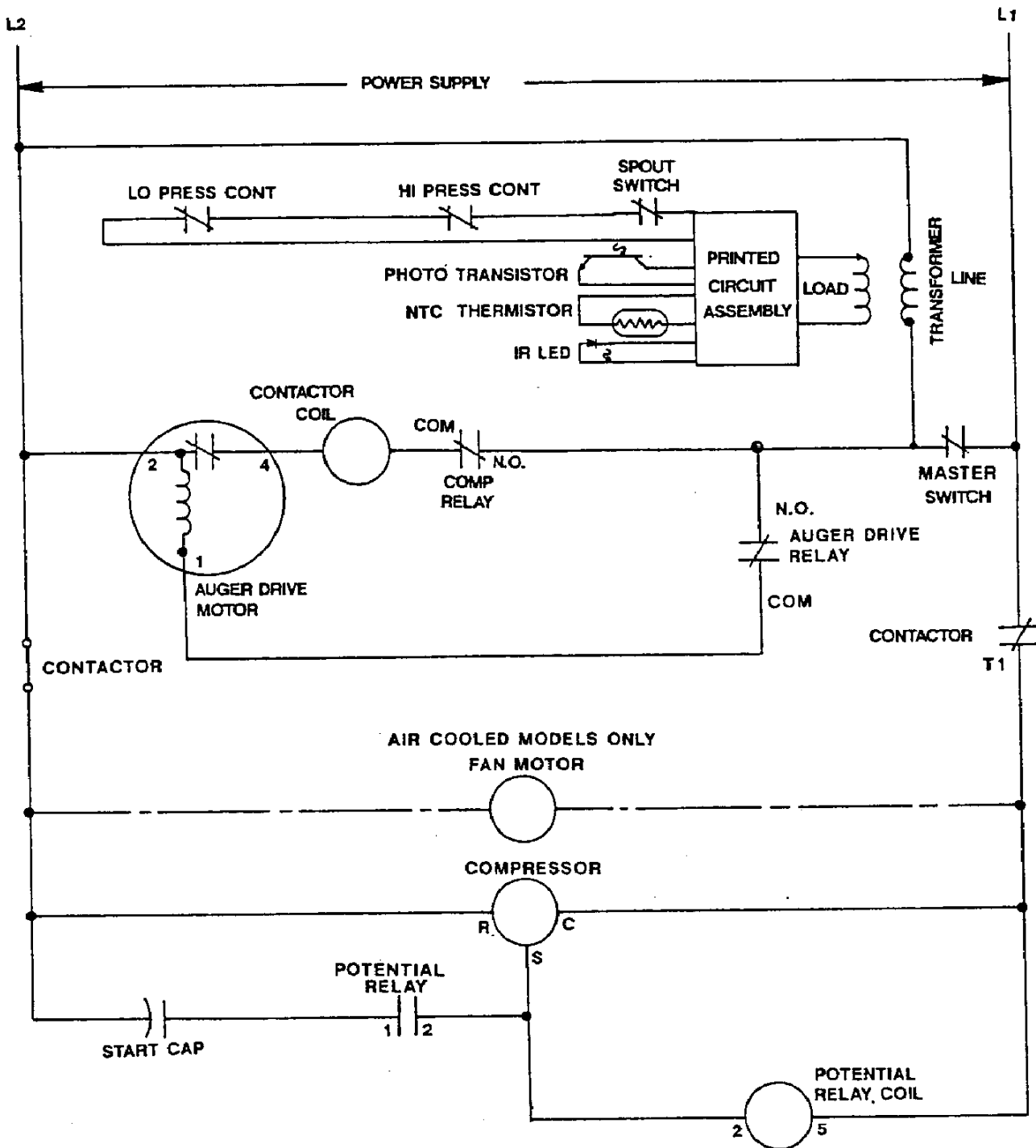

USE COPPER CONDUCTORS ONLY THIS UNIT MUST BE GROUNDED

All Controls Shown in Normal Ice Making Mode.

Note: Dashed lines indicate field wiring which must be installed in accordance with the National Electric Code Using a Minimum of 14 ga. awg. wire.