

HD22 and HD30 Service Parts

This is the list of service parts and wiring diagrams for all versions of these two hotel dispensers.

Pay close attention to the voltage and/or cycles to be sure of ordering the correct part.

Table of Contents

Front and Top Panels	Page 2
HD30B & HD22B Front Panel	Page 3
HD30N and HD30W Front Panel & Related Parts	Page 4
Side, Back and Interior Panels	Page 5
Dispensing Components	Page 6
Ice Chute Mechanism	Page 7
Ice Catch Pan	Page 8
Control Box	Page 9
Wiring Diagram, 115 volt, 60 Hz Basic and Water Station	Page 10
Schematic Diagram, Basic and Water Station Models	Page 11
Wiring Diagram, 230 volt, 50 Hz Basic	Page 12
Wiring Diagram for Coin Mechanism Model	Page 13
Schematic Diagram for Coin Mechanism Model	Page 14

HD22 and HD30 Service Parts

Front and Top Panels

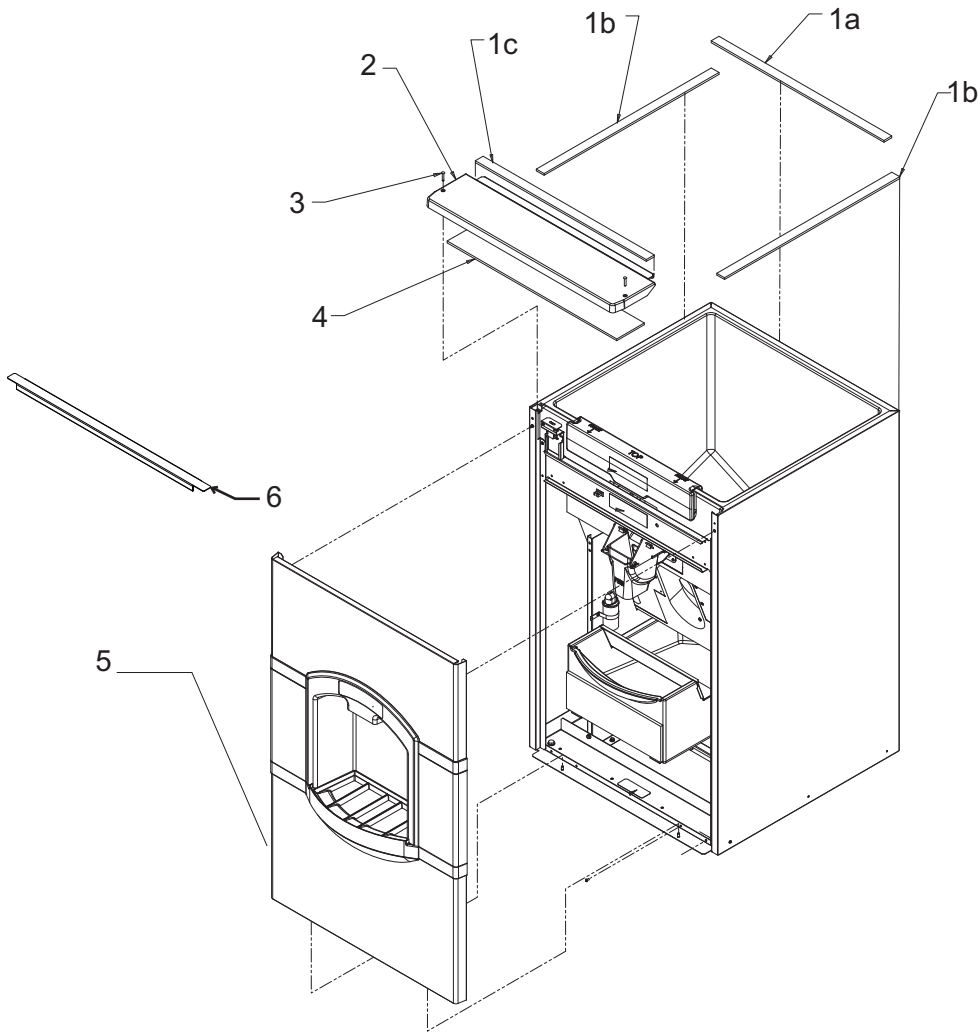

Item Number	Part Number	Description
1	19-0503-04	Gasket tape, order by ft.
1a	Use 27.5" for HD30, 19.5" for HD22	
1b	Use 27.88"	
1c	Use 27.25" for HD30, 19.25" for HD22	
2	02-3997-31	HD30 top panel
	02-3997-33	HD22 top panel
3	03-1735-03	Top panel screw
4	02-3998-01	HD30 panel insulation
	02-3998-02	HD22 panel insulation
5	A38318-021	HD30B or HD30W front panel with side flanges
	A38318-023	HD30N front panel with side flanges
	A38319-021	HD22 front panel with side flanges
6a	A39516-001	HD30 Support brace, use began June 2008, fits slots in top of side panels, slots also added at that time. Kit to add to prior models: A39517-021.
6b	A39517-022	HD22 support brace kit

HD22 and HD30 Service Parts

HD30B & HD22B Front Panel

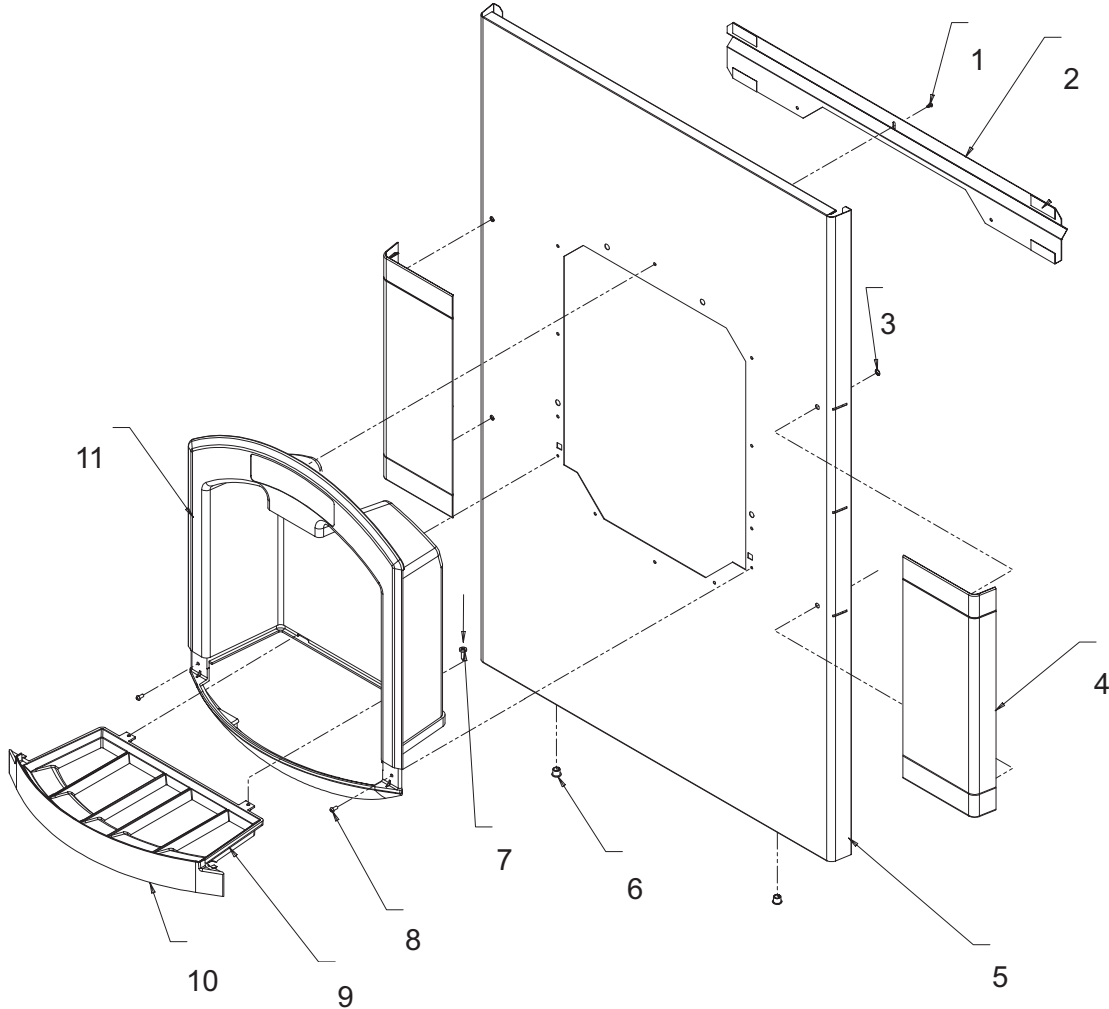

Item Number	Part Number	Description	Item Number	Part Number	Description
1	03-3836-01	Screw	11a	02-3971-31	HD22, HD30B, HD30N dispense housing
2	A38357-001	HD30 stiffener	11b	02-3971-33	HD30W dispense housing
	A38357-002	HD22 stiffener			
3	03-1731-02	Retainer			
4	02-3973-31	HD30B side flange			
	02-3973-32	HD22 side flange			
5	A38318-021	HD30 Front panel*			
	A38319-021	HD22 Front panel*			
6	12-1213-04	Snap bushing			
7	03-1404-12	Screw			
8	03-1531-01	Screw			
9	19-0503-11	Foam gasket, 6" per side			
10	02-3972-31	Grill			

* includes items 1 thru 4

HD22 and HD30 Service Parts

HD30N and HD30W Front Panel & Related Parts

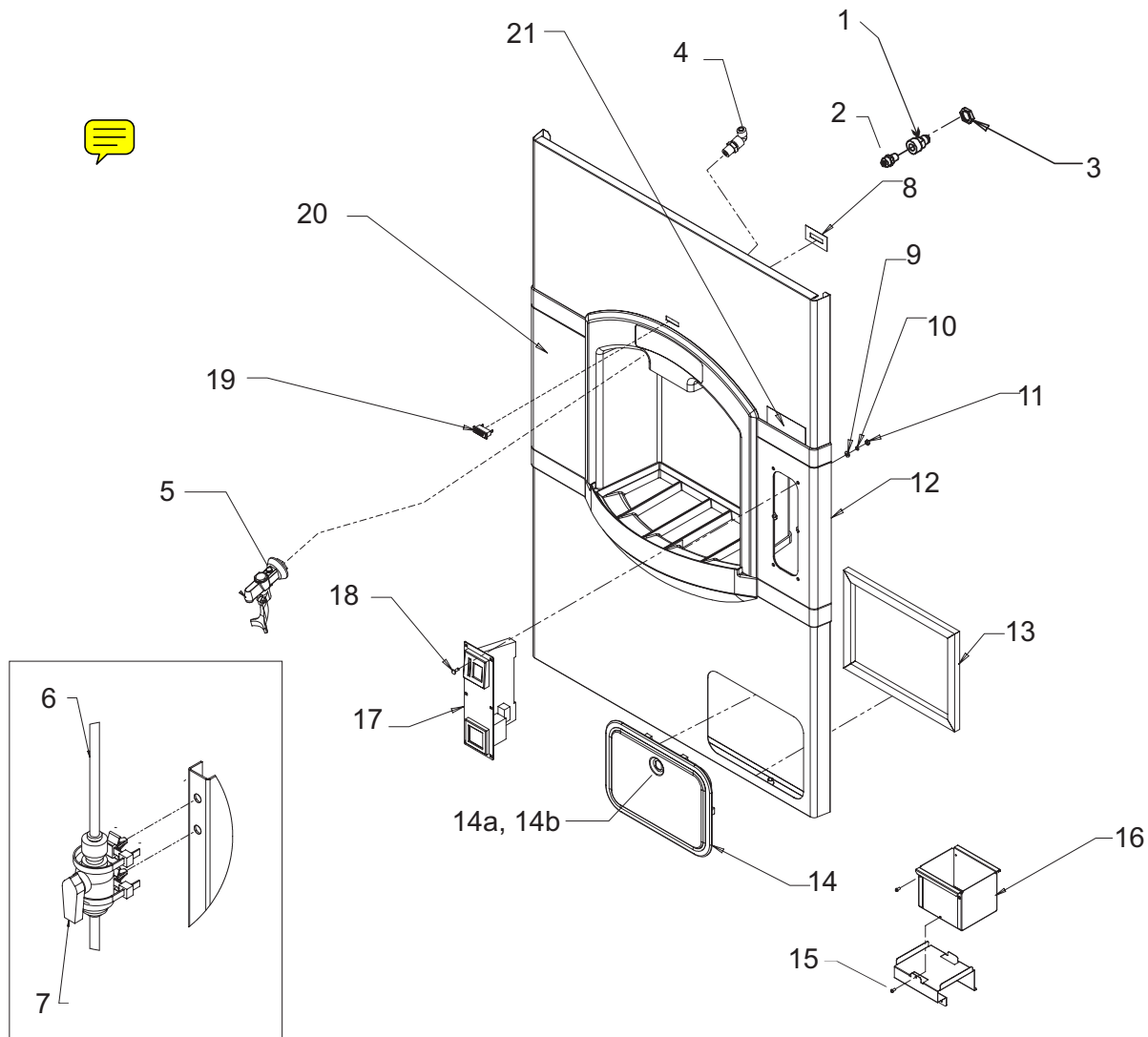

Item Number	Part Number	Description	Item Number	Part Number	Description
1	16-0835-01	Water inlet fitting	12	02-3973-05	Right side flange for coin mech model
2	16-1039-01	Straight connector	13	01-1295-01	Door shim
3	03-1394-01	Pal nut	14	12-2896-02	Door and lock
4	16-1104-01	Male elbow connector	14a	12-2896-26	Lock and key
5	02-3990-01	Water faucet	14b	12-2896-27	Key
6	13-0895-01	Tubing, order per ft	15	03-1531-01	Coin box screw
7	16-1105-01	Shut off valve	16	A38438-001	Coin box
8	A38462-001	Indicator light backing	17	12-2896-01	Coin mechanism
9	03-1407-02	Washer for coin mech		12-2896-25	Coin switch
10	03-1410-07	Lockwasher	18	12-2896-03	Mounting screw
11	03-1406-04	Hex nut (8-32)	19	12-2908-01	Ready light
			20	02-3973-01	HD30 left side flange
			21	17-2970-01	Coin mech label

HD22 and HD30 Service Parts

Side, Back and Interior Panels

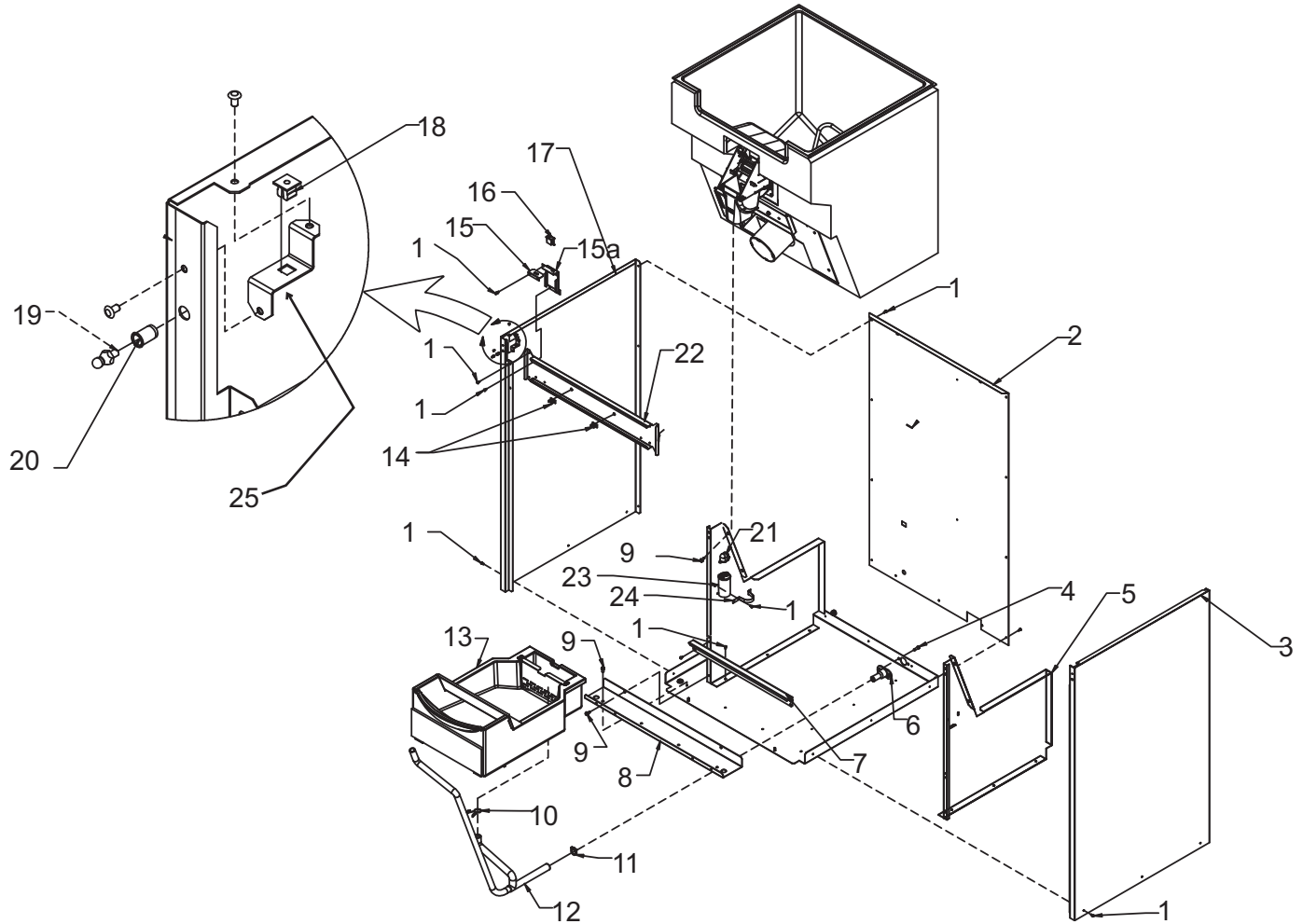

Item Number	Part Number	Description	Item Number	Part Number	Description
1	03-1531-01	Screw	13	A38316-021	Drain pan, assembled
2	A38321-001	HD30 back panel	14	02-3011-01	Wire clamp (coin mech)
	A38322-001	HD22 back panel	15	A38435-002	Switch plate top
3	A38320-022	Right side panel, includes mounting hardware	15a	A38435-001	Switch plate
4	03-0571-01	Screw	16	12-2961-01	Switch, interlock
5	A38325-002	Bin support, right	17	A38320-021	Left side panel, includes mounting hardware
	A38325-001	Bin support, left	18	03-3804-01	Plastic nut
6	02-3692-23	Drain fitting	19	03-1733-01	Strike (ball stud)
7	A38348-001	Catch pan support	20	03-1734-01	Insert
8	A38362-001	HD30 base stiffener	21	13-0666-00	Terminal cover
	A38362-002	HD22 base stiffener	22	A38333-001	HD30 support bracket
9	03-1645-01	Screw		A38333-002	HD22 support bracket
10	02-3791-01	Hose clamp	23	18-1902-52	Motor capacitor
11	02-2814-09	Hose clamp	24	A35971-001	Strap
12	02-3979-01	Drain hose	25	A38363-001	Clip

HD22 and HD30 Service Parts

Dispensing Components

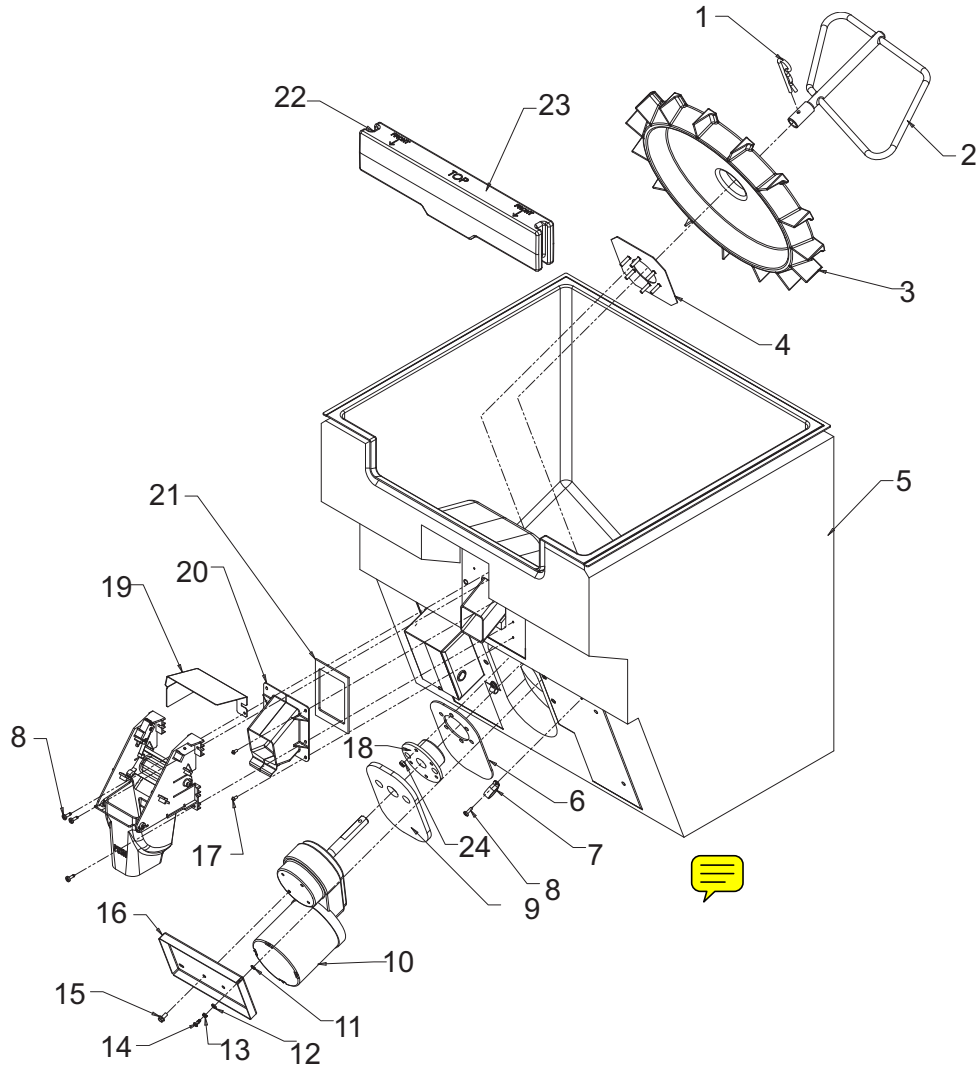

Item Number	Part Number	Description
1	03-3837-01	Hitch pin
2	02-3989-01	Sweep arm
3	02-3040-01	Dispense rotor
4	A38145-001	Hub plate
5	A38314-001	HD30 bin assembly
	A38314-002	HD22 bin assembly
6	13-0940-01	Insulation pad
7	03-3841-02	Loop clamp
8	03-1404-12	Screw
9	13-0939-01	Insulation for hub
10	12-2897-01	Dispense gearmotor, dual voltage
11	03-1731-02	Retainer
12	03-1731-04	Cupped washer
13	03-1731-03	Spring
14	03-3838-02	¼ turn stud
15	03-1645-01	Screw
16	A38342-001	Mounting plate
17	03-1531-01	Screw
18	A34760-001	Hub
19	A38446-001	Switch guard
20	02-3965-01	Spout
21	02-4000-01	Gasket
22	19-0503-09	Gasket, 4" each end
23	A38341-002	Bin door
24	03-1406-08	Nut

HD22 and HD30 Service Parts

Ice Chute Mechanism

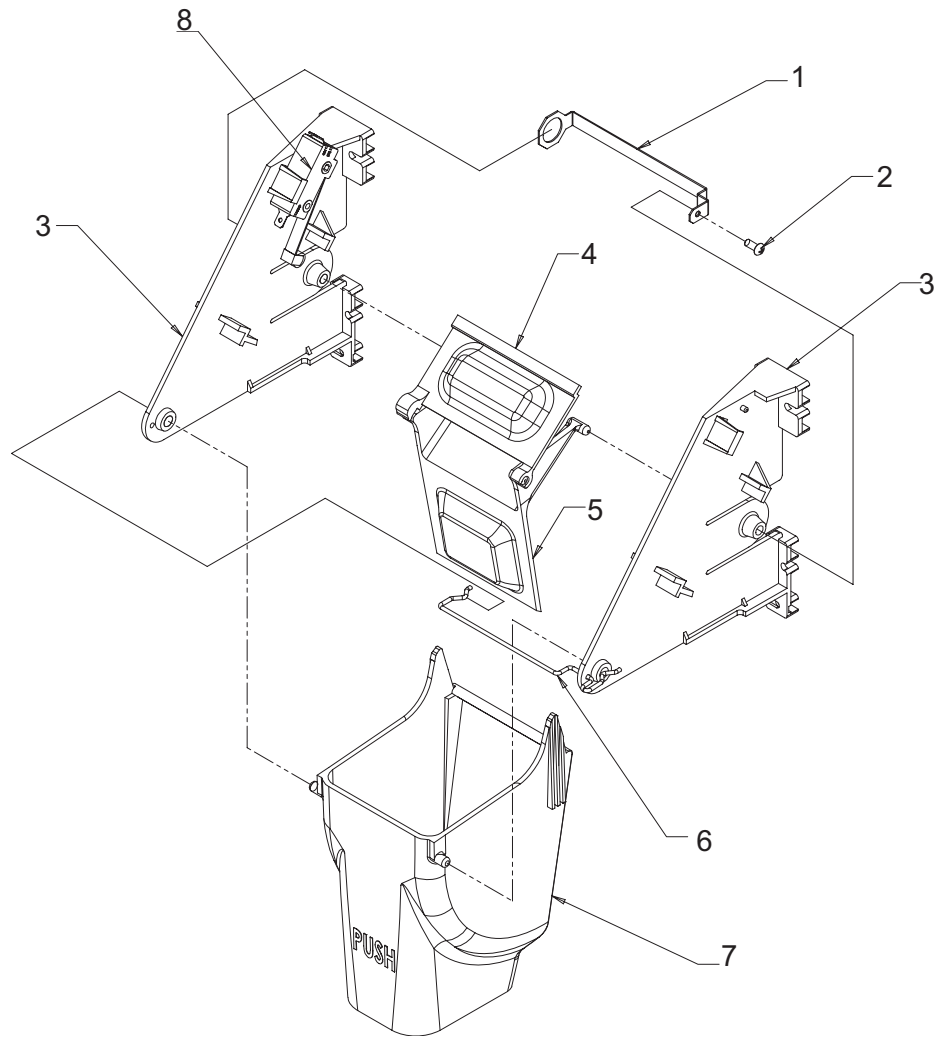

Item Number	Part Number	Description
1	A38455-001	Clip
2	03-1531-01	Screw
3	02-3964-01	Bracket
4	02-3963-01	Door lock
5	02-3962-01	Door
6	02-3970-01	Wire
7	02-3961-01	Dispense chute
8	12-2879-01	Vend switch, 60 Hz
	12-2958-01	Vend switch, 50 Hz, CE only

HD22 and HD30 Service Parts

Ice Catch Pan

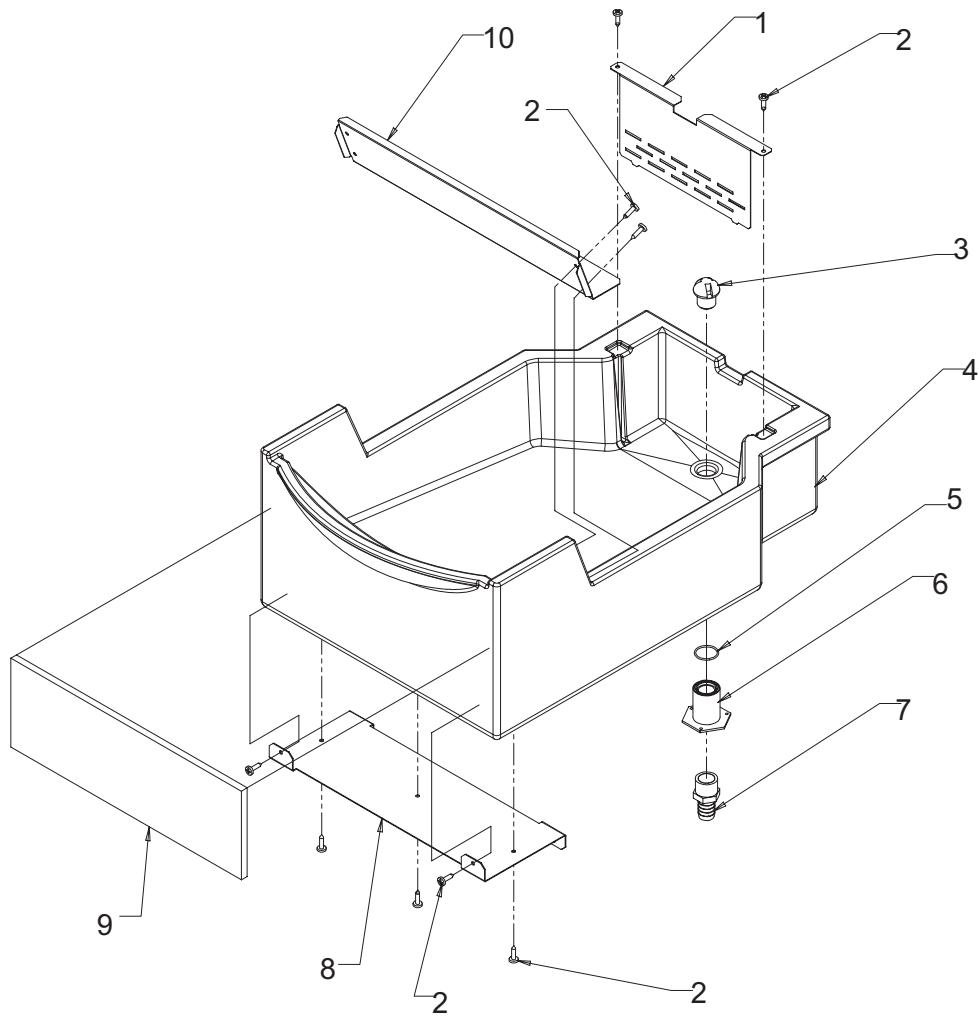

Item Number	Part Number	Description
1	A38332-001	Screen
2	03-1404-12	Screw
3	02-2809-02	Drain top
4	A38316-021	Complete assembly as shown
5	02-4193-01	Flat washer
6	02-3201-01	Drain bottom
7	16-1099-01	Drain fitting
8	A38454-001	Drain pan bracket
9	02-3999-01	Foam pad
10	A38447-001	Drain guard

HD22 and HD30 Service Parts

Control Box

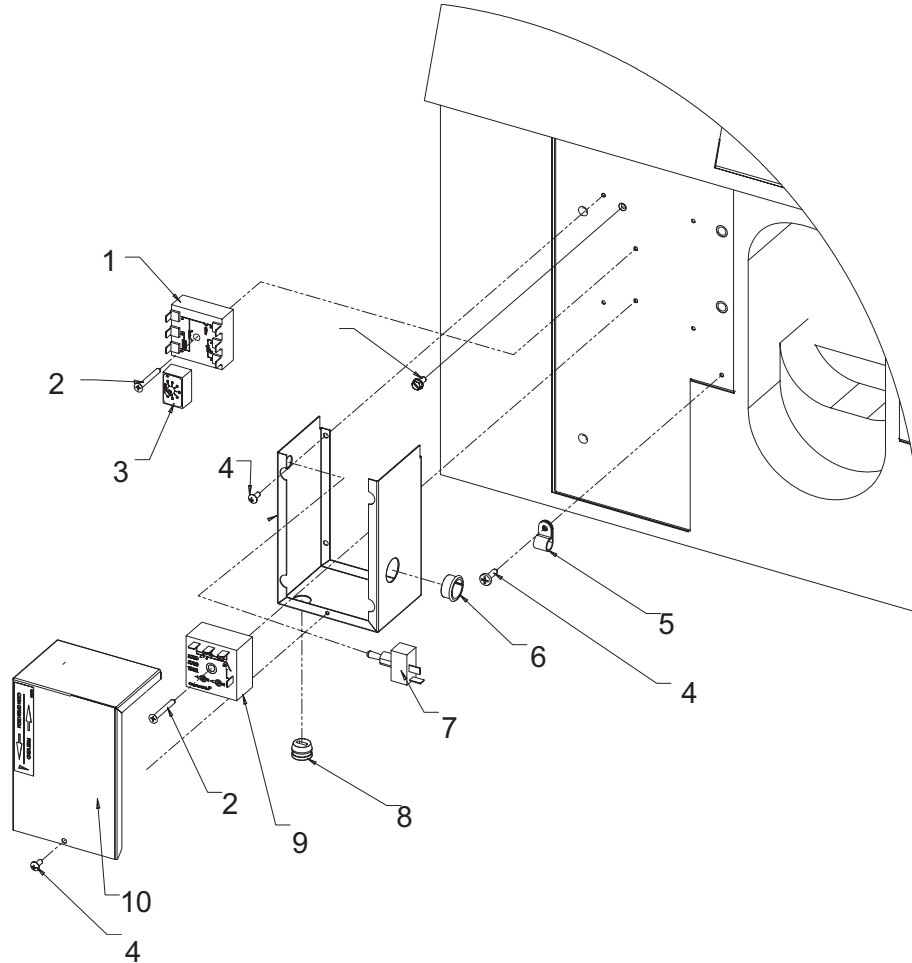

Item Number	Part Number	Description	Not shown		
1	12-2948-21	Coin mech timer*	11	12-2880-01	60 Hz harness, basic and water
2	03-1419-16	Screw		12-2891-01	Coin mech harness
3	part of item 1			12-2904-01	50 Hz harness
4	03-1531-01	Screw	12	12-1638-20	115 volt power cord
5	03-3841-01	Loop clamp		12-1638-18	230 volt power cord
6	12-1213-10	Snap bushing			
7	12-0426-01	Free vend switch			
8	12-0629-08	Strain relief			
9	12-2881-01	60 Hz off cycle timer			
	12-2881-02	50 Hz off cycle timer			
10	A38330-001	Control box cover			

* Note: Use of this timer includes a wiring change. Prior timers had separate adjustment modules and used the wiring diagram on page 13. Refer to page 15 for wiring of this timer.

HD22 and HD30 Service Parts

Wiring Diagram, 115 volt, 60 Hz Basic and Water Station

17-2956-01

ALL CONTROLS SHOWN IN
NORMAL ICE DISPENSING MODE

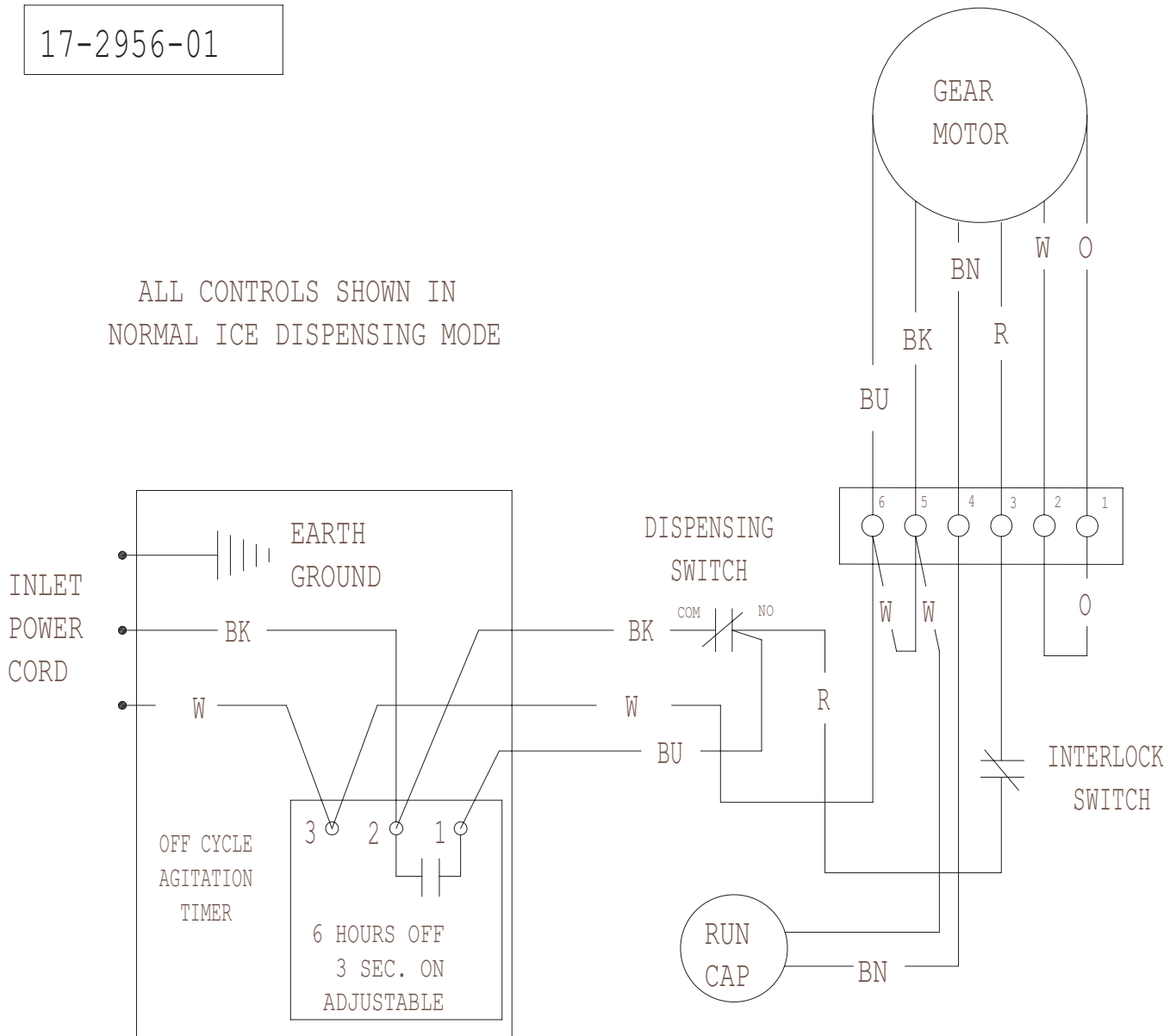

USE COPPER CONDUCTORS ONLY

HD22 and HD30 Service Parts

Schematic Diagram, Basic and Water Station Models

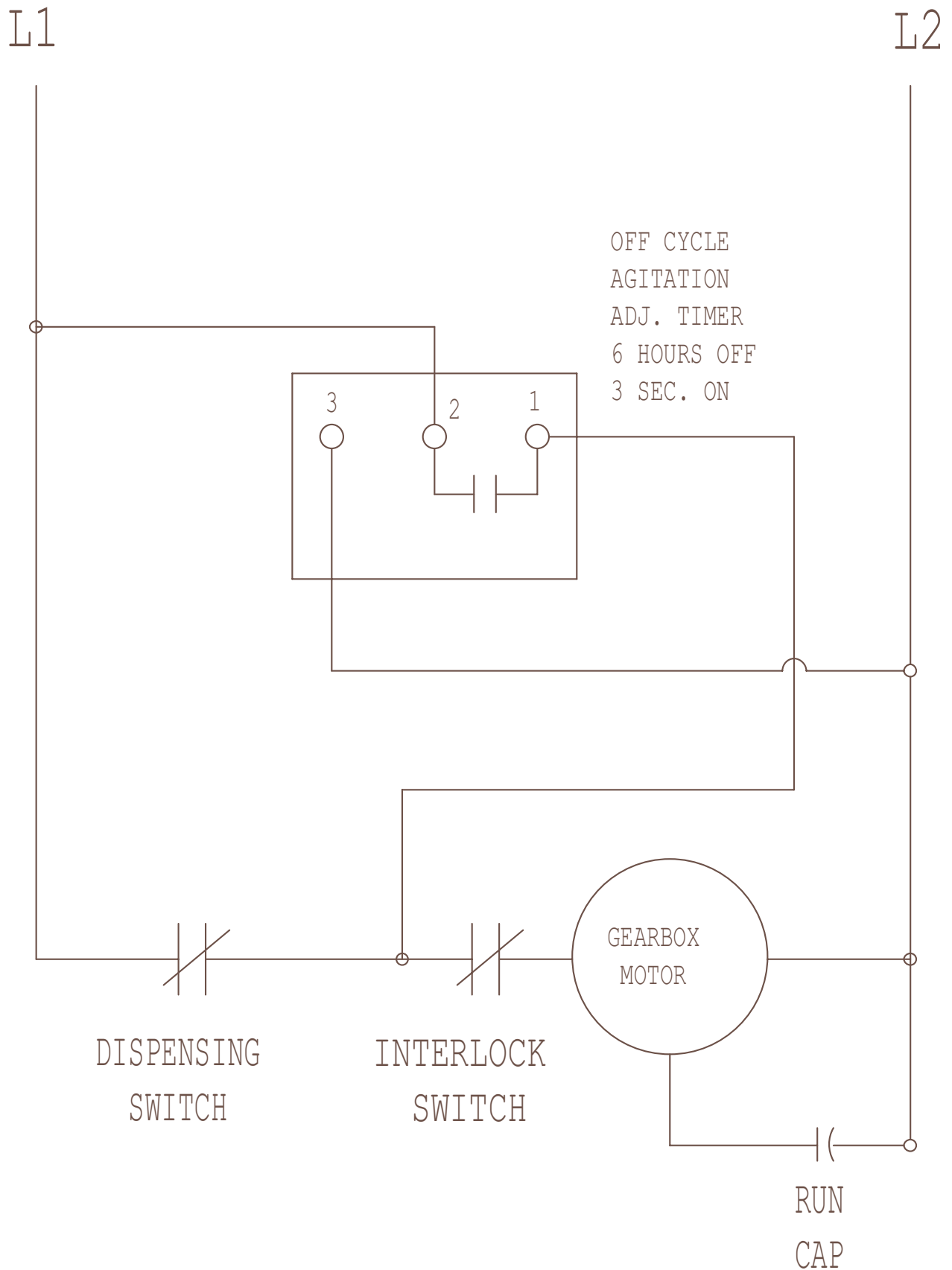

HD22 and HD30 Service Parts

Schematic Diagram for Coin Mechanism Model

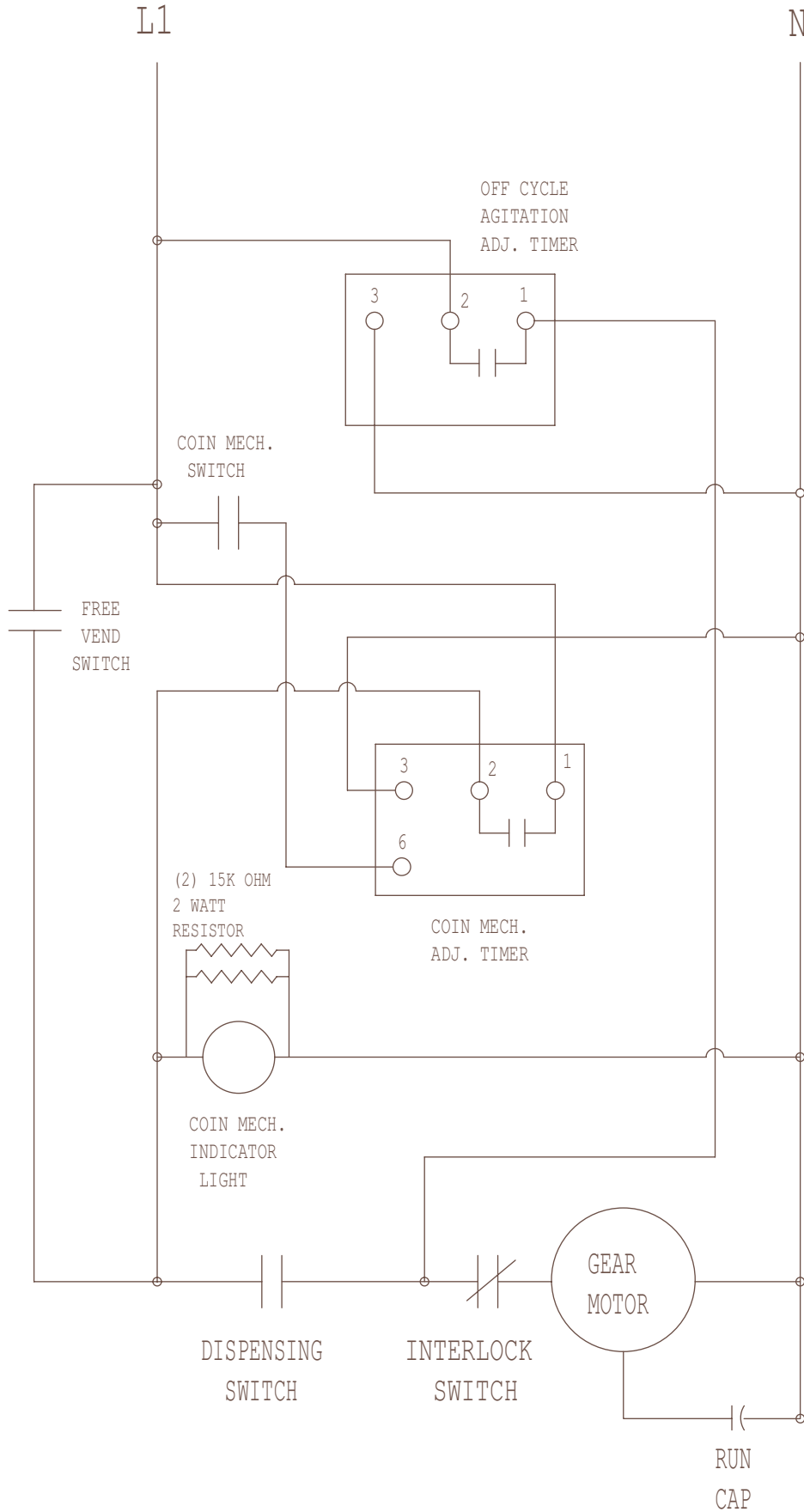

SERVICE BULLETIN

Subject: HD30 Coin Mech Timer Change

The timer used by the HD30 coin vending model to time out the vend has been changed. It was a two part timer, but now is a single piece.

The change began with units produced 12/15/2005.

The prior timer parts are obsolete and no longer available. The new timer can be used in place of the old one by switching the position of the two wires on terminals 1 and 2. Refer to the tables below.

The new timer is part number **12-2948-21**

Wire Connections to Prior Timer	
Wire Color	Terminal Numbers
BK and R/W	1
BK	2
W/BU	3
O	6

Wire Connections to Current Timer	
Wire Color	Terminal Numbers
BK	1
BK and R/W	2
W/BU	3
O	6