

C1448, C1848, C2148 Service Parts

This part list contains the service parts for the air cooled, water cooled and remote air cooled C1448, C1848, C2148 ice machines.

To avoid costly and time consuming errors, double check the model and voltage before ordering a part.

The above have been manufactured in several voltages, which are designated by a voltage code after the hyphen (-) in the model number. Codes used included:

- 32 = 208-230/60/1
- 3 = 208-230/60/3
- 6 = 230/50/1
- 63 = 230/380-420/50/3

There was also a panel change in late 2009, denoted by a B at the end of the model number.

Note: These abbreviations are used in this list:

- AC = Air Cooled
- WC = Water Cooled
- RC = Remote Cooled
- HGV = Hot Gas Valve
- TXV = Thermostatic Expansion Valve
- Volt = Voltage
- Sol Vlv = Solenoid Valve
- Hdwe = Hardware

Table of Contents

Cabinet - <u>A Series</u>	Page 2
Cabinet - <u>B Series</u>	Page 3
Interior Parts	Page 4
Evaporator Compartment	Page 5
Air Cooled Refrigeration System	Page 6
Air Cooled Mechanical & Electrical	Page 7
Water Cooled Refrigeration System	Page 8
Remote Refrigeration System	Page 9
Electrical & Control Box - 3, -6, -32	Page 10
Electrical & Control Box, 400 volt, 50 Hz. 3 phase w/neutral (-63)	Page 11
Compressors	Page 12
Compressor Mounting Hardware	Page 12
Crankcase Heaters	Page 12
Remote Condenser, ERC311 and ERC611	Page 13

Scotsman
800-533-6006
www.scotsman-ice.com

C1448, C1848, C2148 Service Parts

Cabinet - A Series

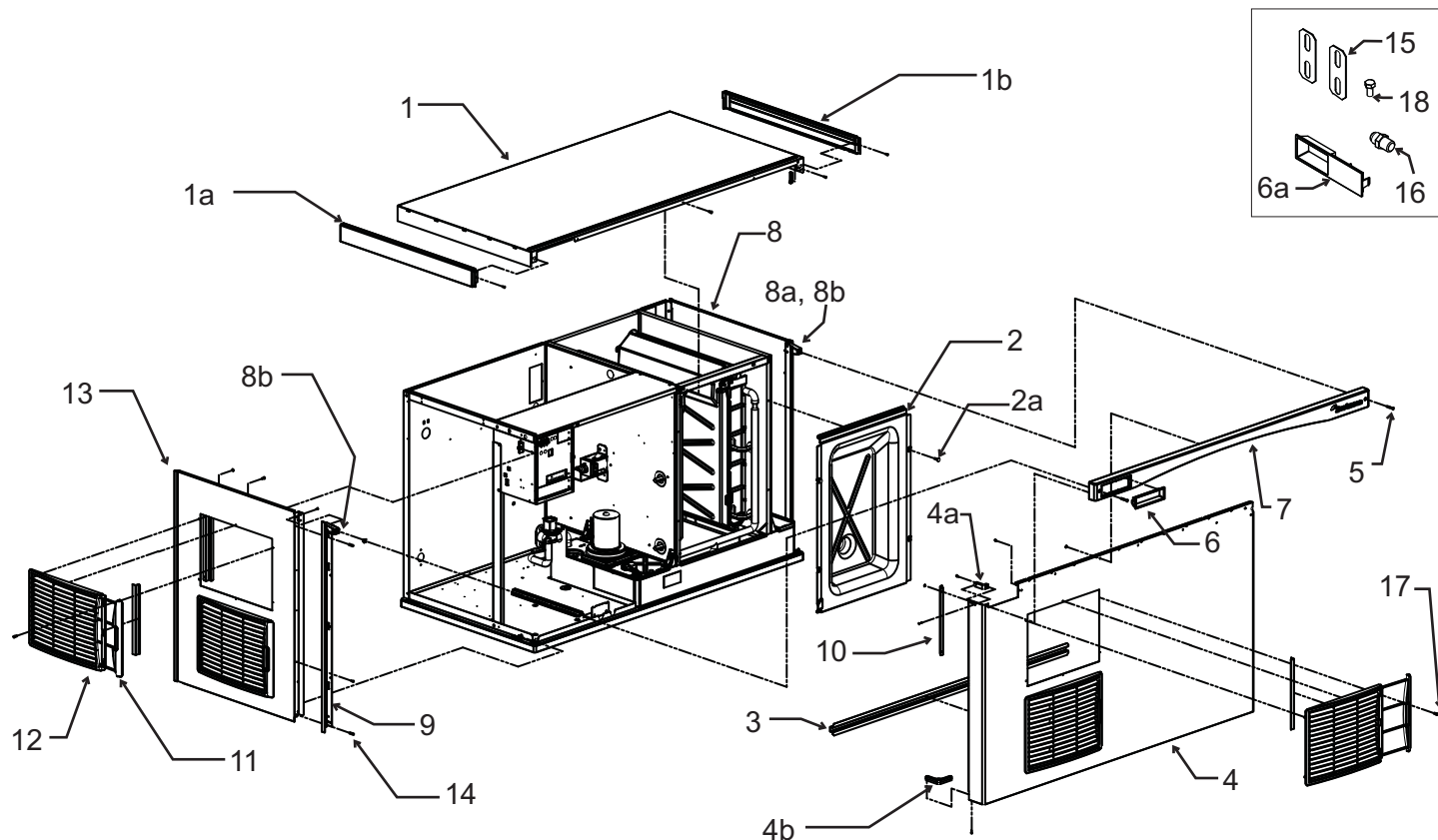

Item Number	Part Number	Description
1	A38941-023	Top panel, w/trim strips
1a	02-4221-01	Left trim strip
1b	02-4221-02	Right trim strip
2	02-4184-01	Evaporator cover
2a	03-0727-05	Screw
3	A39045-001	Front panel stiffener
4	A38552-025	AC Front panel assembly, includes filters, trim strip, gussets and labels.
4a	02-4216-01	Top gusset
4b	02-4217-01	Bottom gusset
5	03-1735-03	Screw, front panel
6	02-4284-01	Bezel, full window
6a	02-4284-02	Bezel, partial window
7	02-4214-03	Trim strip
8	A38553-022	Right side panel assy
8a	02-4215-01	Receptacle
8b	03-3804-01	Screw receptacle
9	02-4067-03	Side panel support. Fits water cooled and remote models. Used as back side panel support for air cooled.
	02-4067-04	Front side panel support for air cooled models
10	A39222-001	Filter guide
11	02-4212-01	Air filter
12	02-4224-01	Louver panel
12a	A39238-001	Louver bracket
13	A38551-023	Left side panel, AC
	A38551-024	Left side panel WC, RC
14	03-1404-12	Screw
15	A30911-015	Machine straps
16	16-0355-00	Inlet water fitting, flare
17	03-1419-17	Flat head screw
18	03-1405-15	Screw

C1448, C1848, C2148 Service Parts

Cabinet - B Series

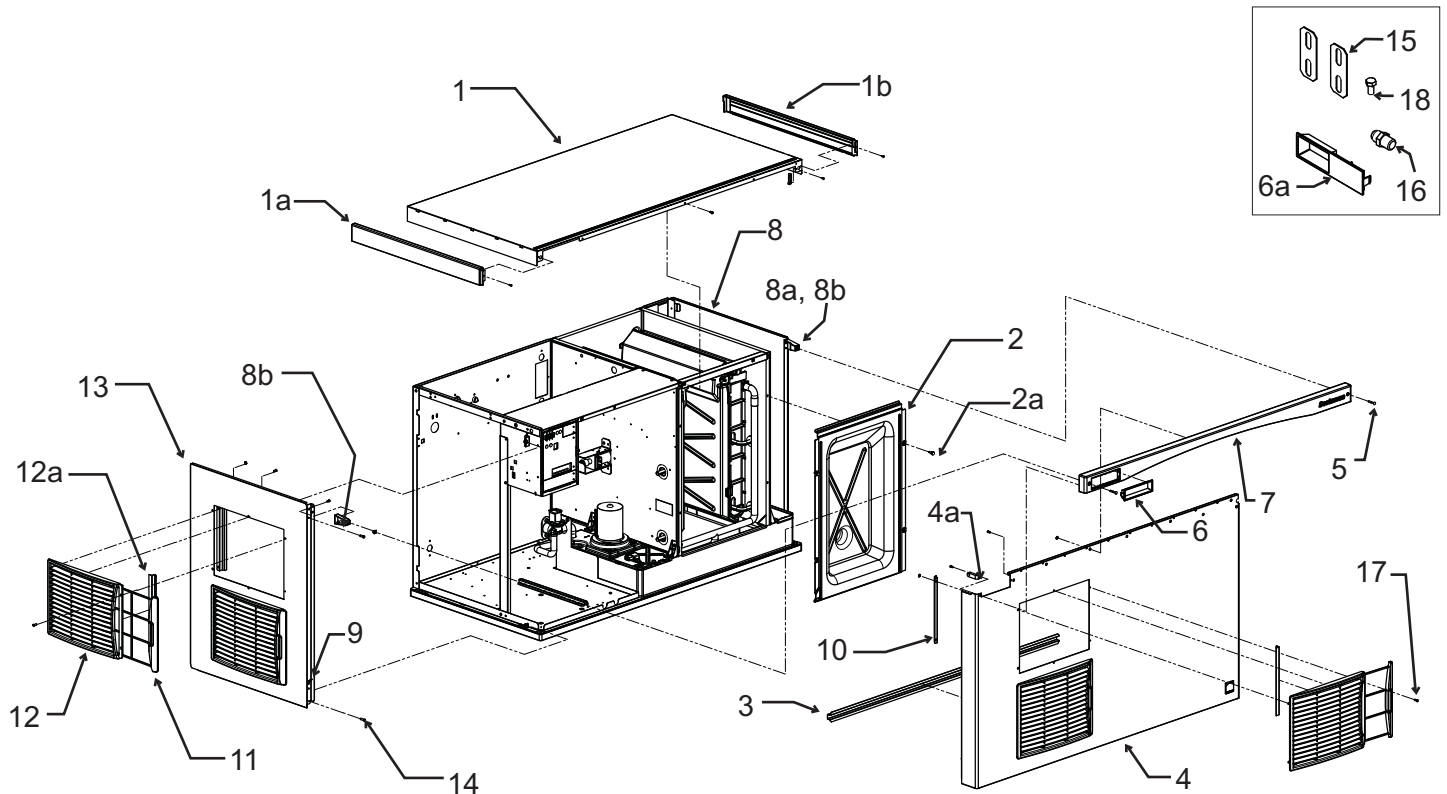

Item Number	Part Number	Description	Item Number	Part Number	Description
1	A39579-023	Top panel, w/trim strips	8b	03-3804-01	Screw receptacle
1a	02-4221-01	Left trim strip	9	A39571-001	Panel clip
1b	02-4221-02	Right trim strip	10	A39222-001	Filter guide
2	02-4184-01	Evaporator cover	11	02-4212-01	Air filter
2a	03-0727-05	Screw	12	02-4224-01	Louver panel
3	A39045-001	Front panel stiffener	12a	A39238-001	Louver bracket
4	A39578-025	AC Front panel assembly, includes filters, trim strip, gussets	13	A39580-026	Left side panel, AC
4a	02-4216-01	Top gusset		A39580-024	Left side panel, WC, RC
5	03-1735-03	Screw, front panel	14	03-1404-12	Screw
6	02-4284-01	Bezel, full window	15	A30911-015	Machine straps
6a	02-4284-02	Bezel, partial window	16	16-0355-00	Inlet water fitting, flare
7	02-4214-03	Trim strip	17	03-1419-17	Flat head screw
8	A39581-022	Right side panel assy	18	03-1405-15	Screw
8a	02-4215-01	Receptacle			

C1448, C1848, C2148 Service Parts

Interior Parts

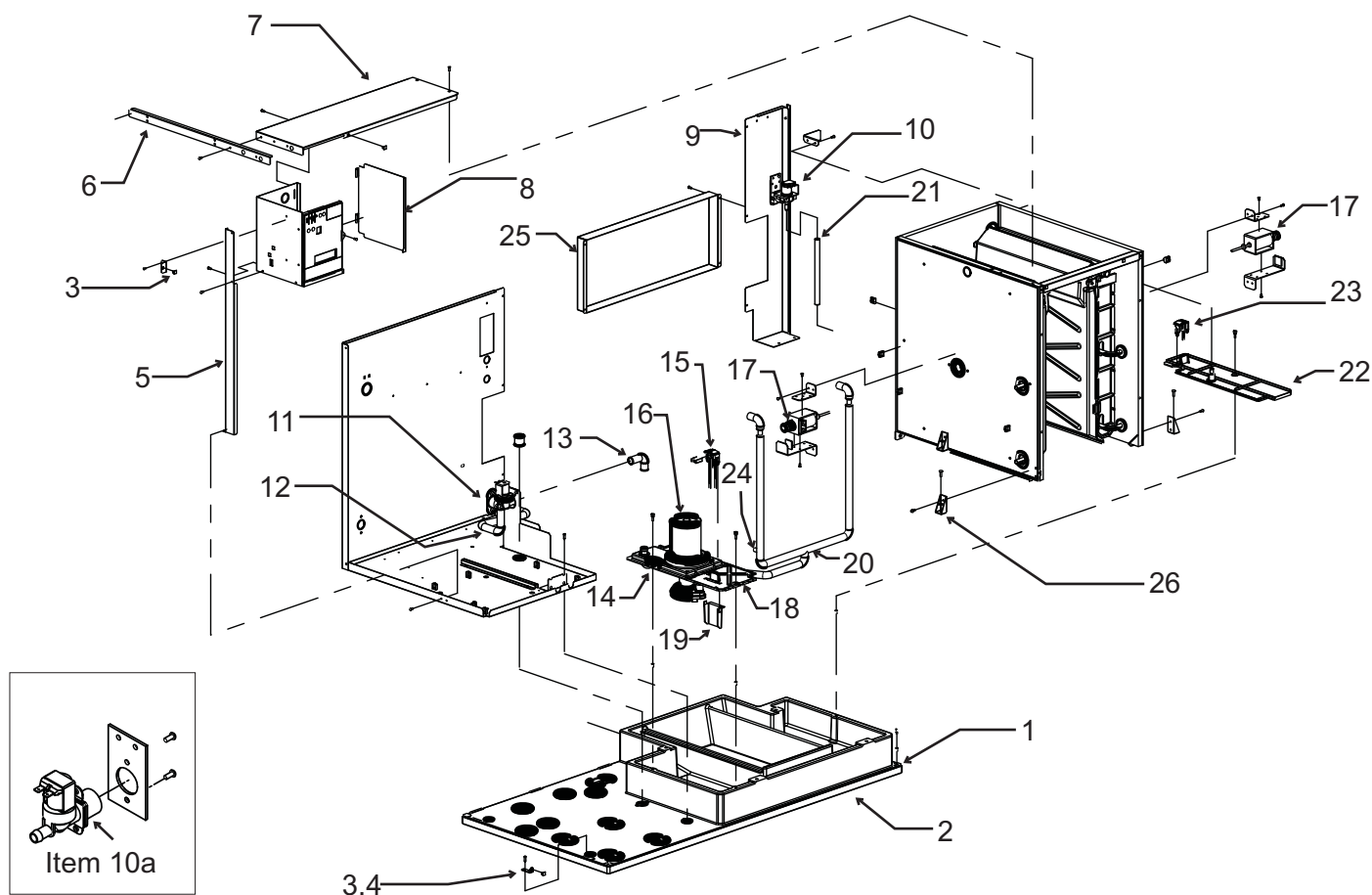

Item Number	Part Number	Description		Part Number	Description
1	15-0411-00	Strike - A series only		15	A39030-021 Water level sensor WLS harness, see page 9
2	no number	Base, insulated		16	12-2920-22 Water pump
3	03-3804-01	Receptacle		17	12-3036-22 Harvest assist solenoid
4	A38732-001	Side panel mount		18	02-4178-01 Reservoir cover
5	A38629-001	Strut		19	02-4332-01 Sensor cover
6	A38582-001	Brace		20	02-4182-01 Pump hose
7	A39281-001	Control box top		21	13-0674-02 Fill hose order by ft (18") 15-0821-01 Fill hose, -6 CE models
8	A38537-001	Control box side		22	02-4175-01 Rt side res cover
9	A38680-001	Right back panel		23	A39030-022 Level sensor
10	12-2922-02 12-2912-01	Inlet water sol vlv, 230 volt Water valve rebuild kit		24	11-0572-21 Temp probe assy
10a	11-0568-02	Inlet water sol vlv, CE mod		25	A38681-001 Chase cover
11	11-0564-02	Purge valve, 230 volt		26	02-4152-01 Gusset
12	A38862-002	Drain tube			
13	A38862-001	Drain hose			
14	02-4177-01	Water pump bracket			

C1448, C1848, C2148 Service Parts

Evaporator Compartment

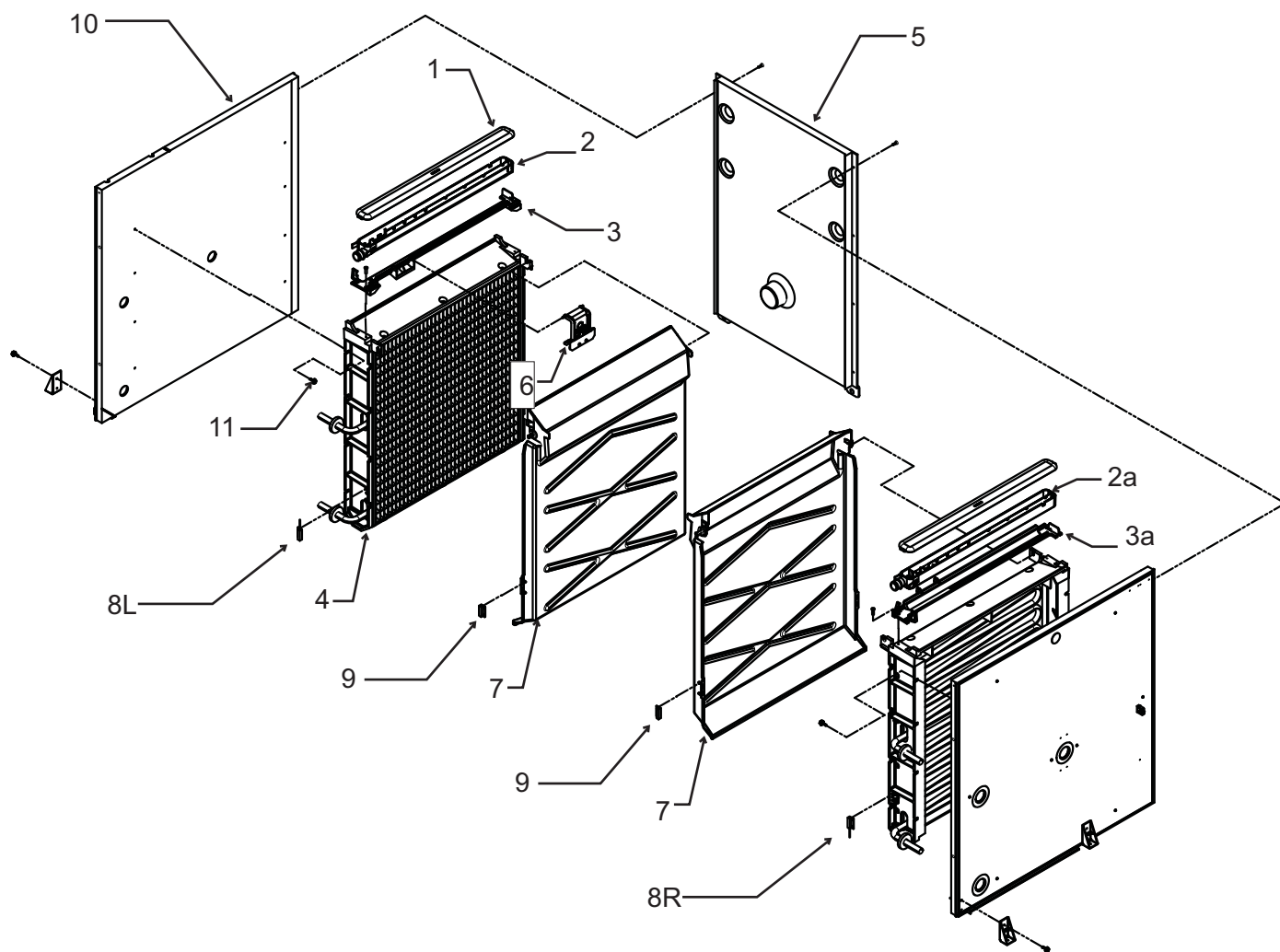

Item Number	Part Number	Description	Item Number	Part Number	Description
1	02-4065-01	Water distributor cover	6	A39031-021	Ice thickness sensor
2	02-4064-01	Water distributor, left	7	02-4100-33	Curtain
2a	02-4064-02	Water distributor, right	8L	11-0563-06	Curtain switch, left
3	02-4205-01	Mounting bracket, left	8R	11-0563-03	Curtain switch, right
3a	02-4205-02	Mounting bracket, right	9	11-0563-02	Curtain switch magnet
4	see table	Evaporator	10	13-0943-01	Gasket tape
			11	03-3868-01	Screw

Note: Item 7 includes item 9, shipped loose.

	small cube	medium cube
Right	A38628-023	A38628-024
Left	A38628-021	A38628-022

5 A38677-001 Back wall

C1448, C1848, C2148 Service Parts

Air Cooled Refrigeration System

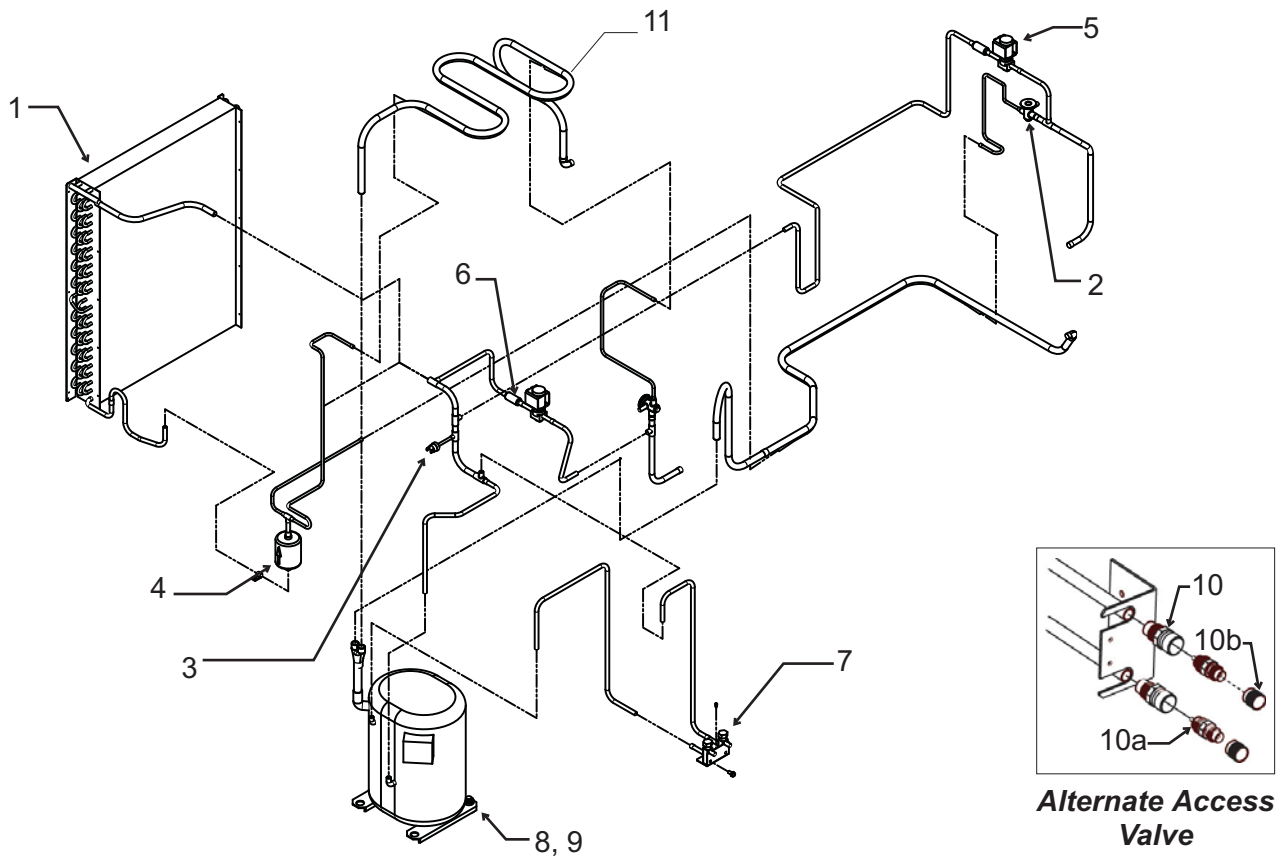

Alternate Access Valve

Item Number	Part Number	Description	Alternate Access Valve, use began 4/08		
1	18-8892-01	Condenser, AC	10	16-1137-01	Valve body
2	16-1130-01	TXV	10a	16-1139-01	Core
	02-4045-01	Insulation Danfoss TXV	10b	16-1140-01	Cap
3	11-0566-22	Fan cycle pressure sw.	11	A38736-001	Left suction line heat ex
4	02-3319-02	Dryer			
5	11-0493-01	Hot gas valve, 230 volt			
	12-2719-22	230 volt coil			
	12-2733-30	HGV rebuild kit			
6	16-1063-01	Strainer			
7	16-0832-20	Access valve			
	16-0832-03	Port cap			
	16-0832-02	Stem cap			
8	see page 10	Compressors			
9	see page 10	Compressor mounting hdw			

C1448, C1848, C2148 Service Parts

Air Cooled Mechanical & Electrical

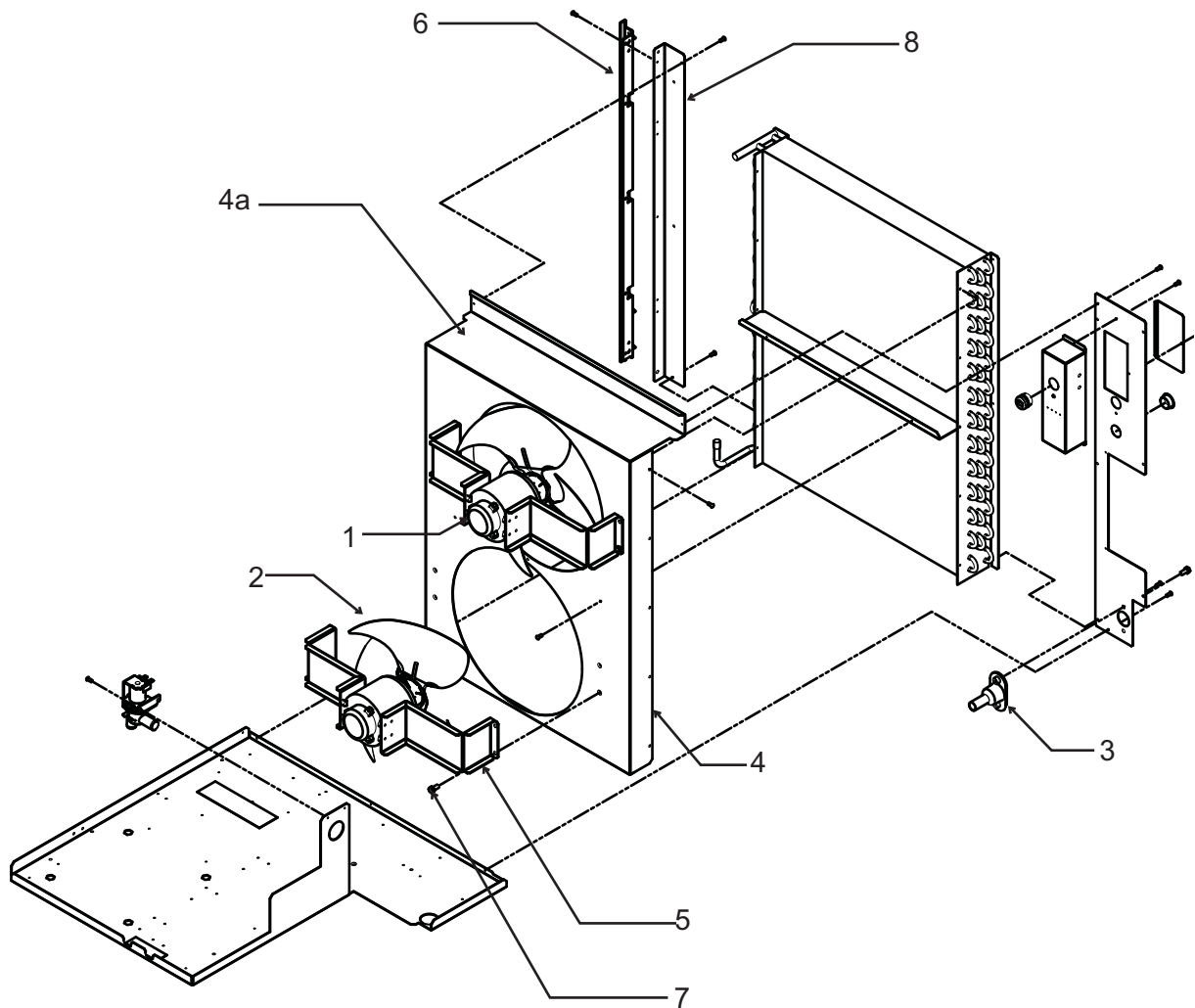

Item Number	Part Number	Description
1	18-8927-01	Fan motor
2	18-8882-01	Fan blade
3	02-3692-21	Drain adapter - also for WC and RC
4	A38682-001	Fan shroud - A Series
	A39630-001	Fan shroud - B Series
4a	A39631-001	Fan shroud top - B series only
5	A38554-001	Fan motor bracket
6	02-4067-04	Side panel support - AC
7	03-1645-01	Screw
8	A38741-001	AC bracket - A Series
	A39590-001	AC bracket - B Series

C1448, C1848, C2148 Service Parts

Water Cooled Refrigeration System

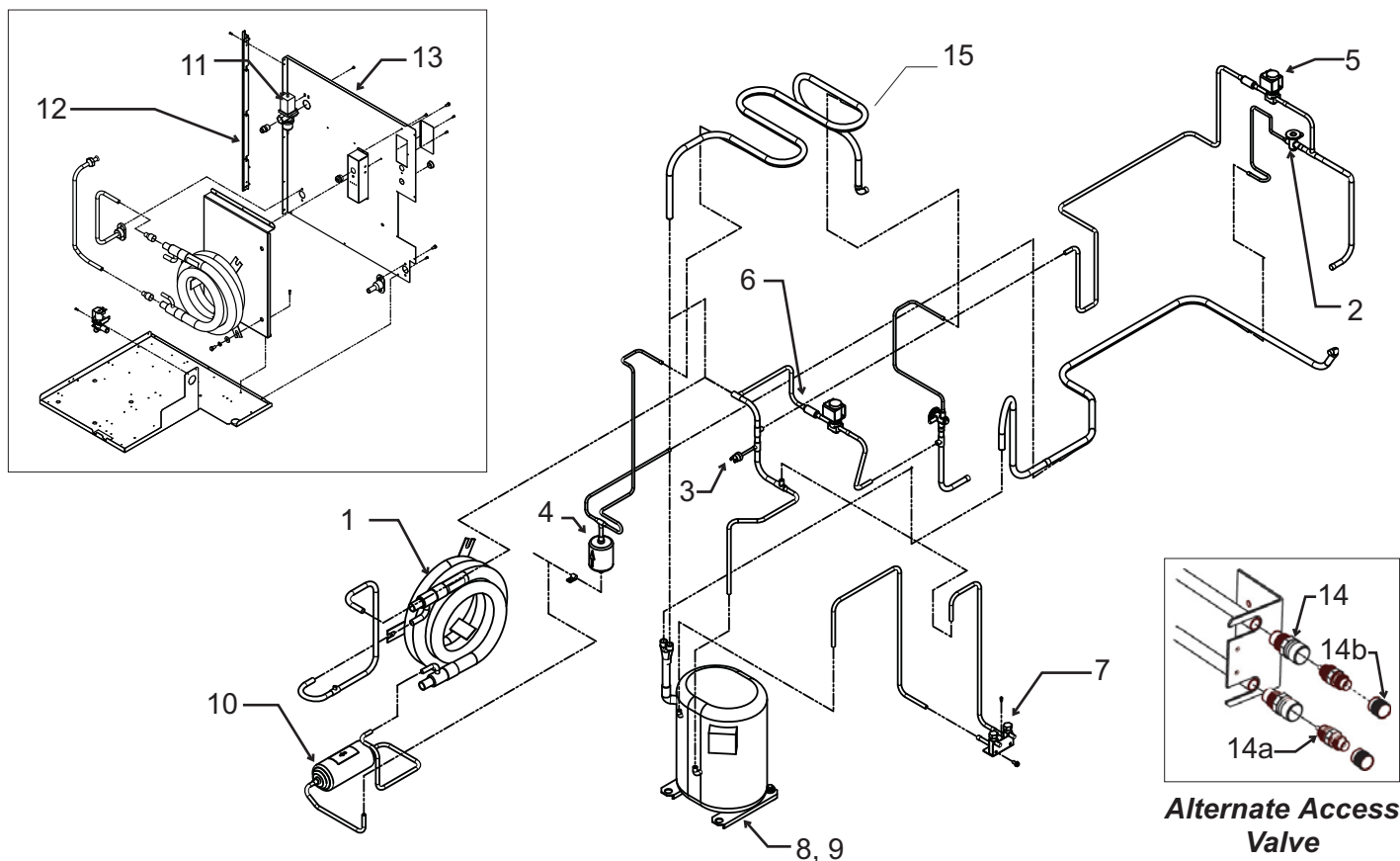

Item Number	Part Number	Description	Part Number	Description
1	18-8865-21	Condenser, WC C1448. C1848	11-0478-01	Water regulating valve, C1448W, C1848W
2	16-1130-01	TXV	11-0478-02	Water regulating valve C2148W
3	11-0501-21	High pressure sw.	12	02-4067-03 Side support
4	02-3319-02	Dryer	13	A38606-001 Back panel, WC - A series
5	11-0493-01	Hot gas valve, 230 volt	A39574-001	Back panel, WC - B series
6	16-1063-01	Strainer	Alternate Access Valve, use began 4/08	
7	16-0832-20	Access valve	14	16-1137-01 Valve body
8	see page 10	Compressors	14a	16-1139-01 Core
9	see page 10	Compressor mounting hdw	14b	16-1140-01 Cap
10	02-2628-02	Receiver	15	A38736-001 Left suction line heat ex

C1448, C1848, C2148 Service Parts

Remote Refrigeration System

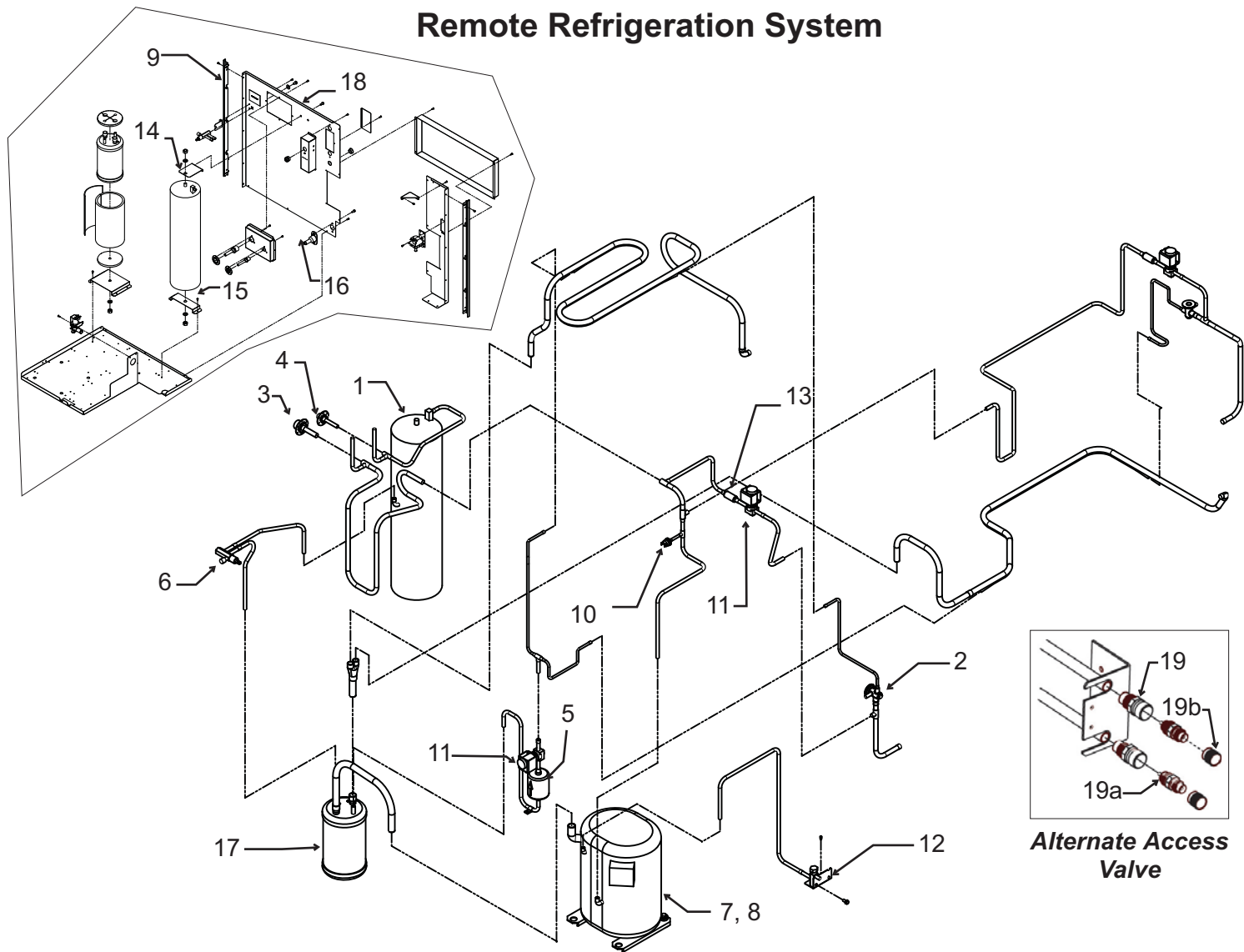

Item Number	Part Number	Description	Item Number	Part Number	Description
1	16-1026-01	Receiver	11	11-0493-01	Liquid line valve or HGV, 230 volt
2	16-1130-01	TXV	12	16-0832-20	Access valve
	02-4045-01	insulation Danfoss TXV		16-0832-03	Port cap
3	16-0850-01	Discharge quick connect		16-0832-02	Stem cap
4	16-0850-03	Liquid quick connect	13	16-1063-01	Strainer
5	02-3319-02	Drier	14	A37211-001	Top receiver bracket
6	16-1030-01	Liquid line access valve	15	A37212-001	Bottom receiver bracket
7	see page 10	Compressors	16	02-3692-21	Drain adapter
8	see page 10	Compressor mounting hdw	17	16-1122-21	Accumulator, kit w/insul
8a	see page 10	Crankcase heater	18	A38679-001	Back panel, rem - A series
9	02-4067-03	Side panel support,		A39574-001	Back panel, rem - B series
10	11-0501-22	High pressure cut out	Alternate Access Valve, use began 4/08		
			19	16-1137-01	Valve body
			19a	16-1139-01	Core
			19b	16-1140-01	Cap

C1448, C1848, C2148 Service Parts

Electrical & Control Box - 3, -6, -32

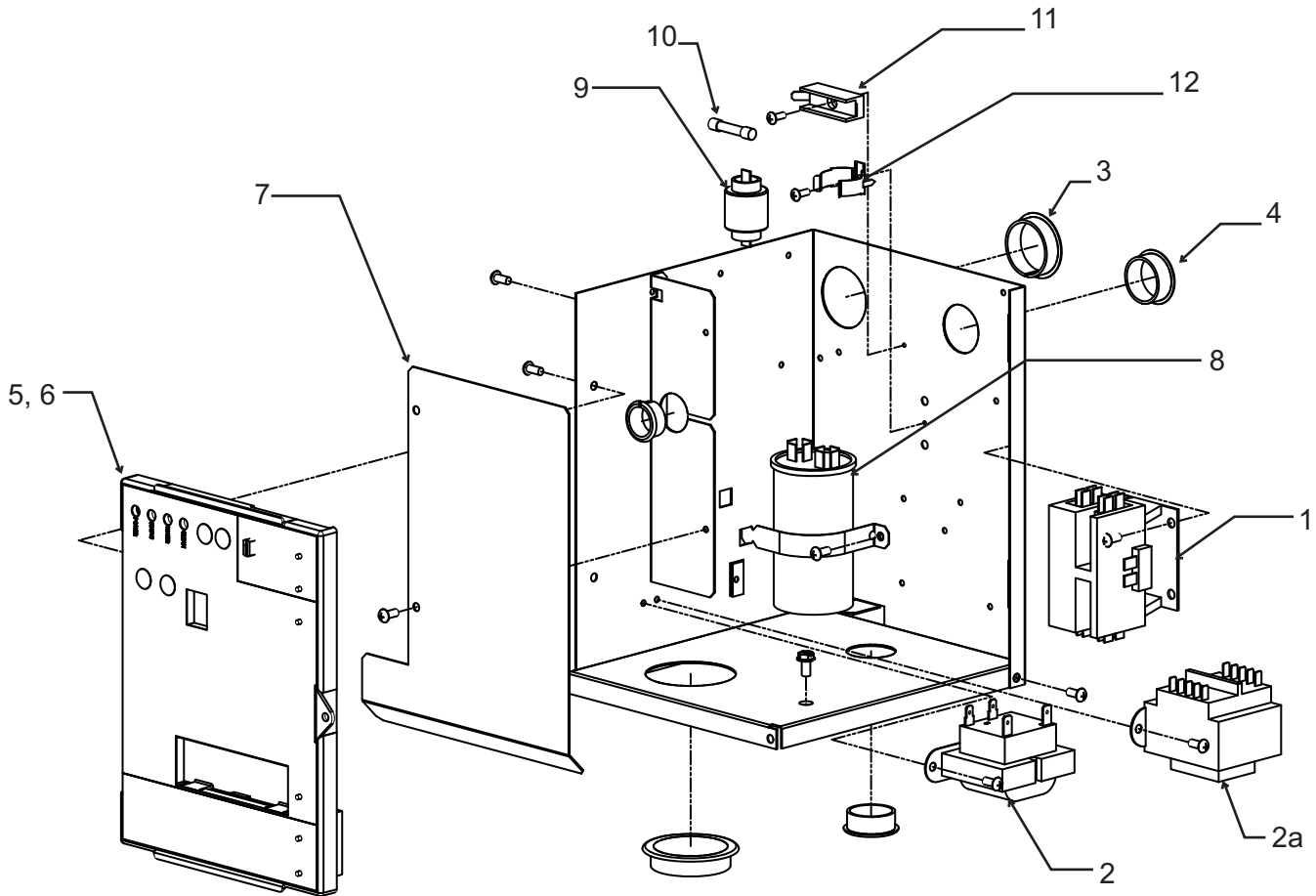

Item Number	Part Number	Description
1	12-2469-02	Contactor, 230, single ph
	12-2533-02	Contactor, three phase
2	12-2924-02	Transformer, 230 volt
2a	12-2639-01	Transformer, 50 Hz
3	12-1213-11	Snap bushing
4	12-1213-15	Snap bushing
5	11-0550-27	Service controller, fits all Prodigy cubers
6	02-4076-01	Control box door
	02-4189-01	Overlay label
7	A39216-001	Barrier
8		see next page Run capacitor
9		see next page PTCR -
10	12-2686-01	Fuse, 50 Hz only
11	12-2687-01	Fuse holder
12	18-8840-02	Bracket
		Wiring Harnesses (not illustrated)
13	12-2931-01	Power harness, A & W
	12-2931-02	Power harness, Remote
		Power harness connects to J1 on controller
14	12-2937-01	Hi voltage harness, A & W
	12-2938-01	Hi voltage harness, Rem
	12-2944-01	Hi voltage, 50 Hz A & W
	12-2944-02	Hi voltage, 50 Hz, Rem
		Hi voltage harness has the 8 pin connector
15	12-2928-02	Water level sensor harness

C1448, C1848, C2148 Service Parts

Electrical & Control Box, 400 volt, 50 Hz. 3 phase w/neutral (-63)

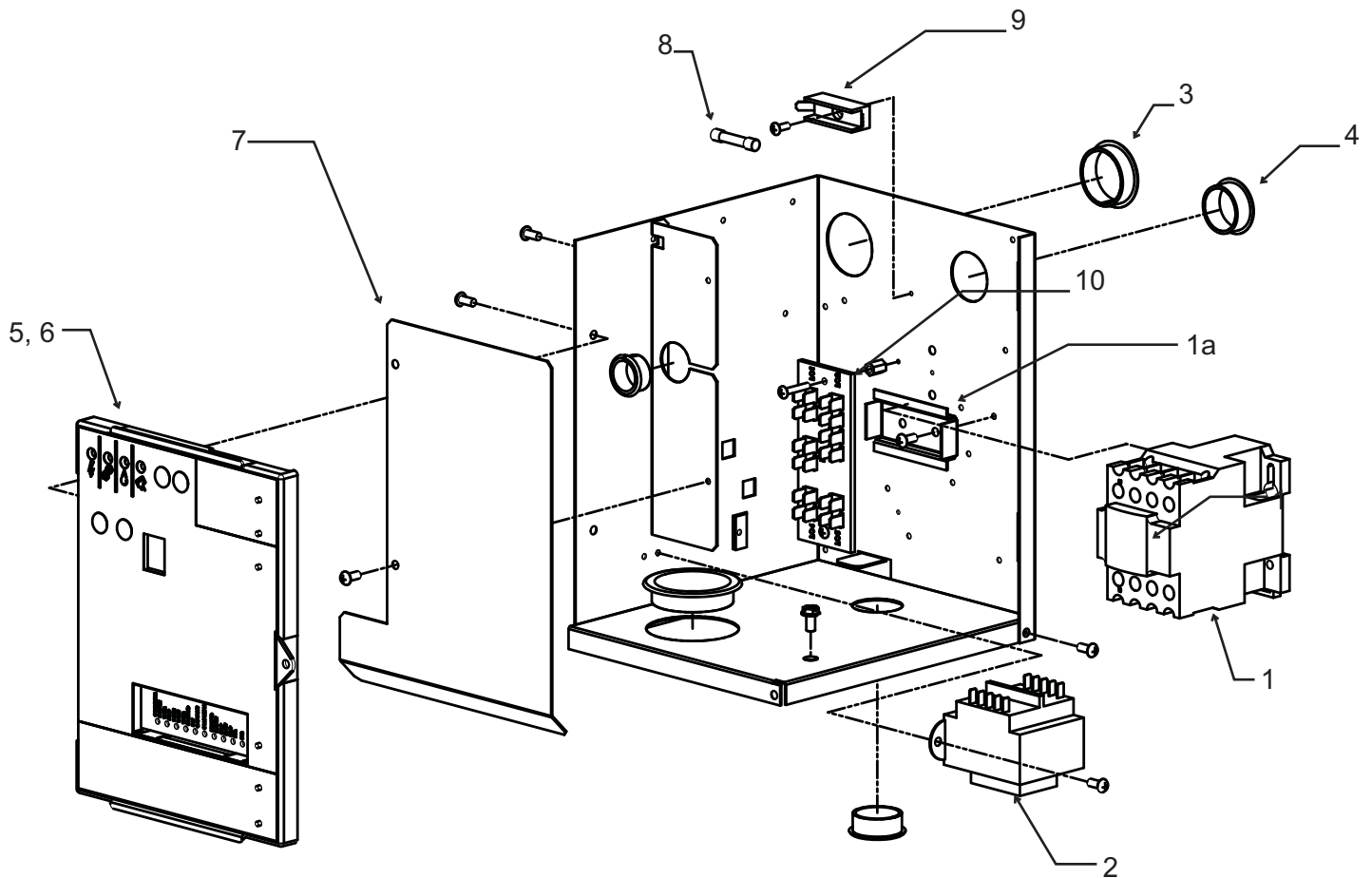

Item Number	Part Number	Description
1	12-3010-01	Contactors, 400 v 3 ph.
1a	A39511-001	Bracket
2	12-2639-01	Transformer, 50 Hz
3	12-1213-11	Snap bushing
4	12-1213-15	Snap bushing
5	11-0550-27	Service controller, fits all Prodigy cubers
6	02-4076-01	Control box door
	02-4189-01	Overlay label
7	A39216-001	Barrier
8	12-2686-01	Fuse, 50 Hz only
9	12-2687-01	Fuse holder
10	A25981-001	Terminal board

Wiring Harnesses (not illustrated)

11	12-2944-02	Hi voltage, 50 Hz, Rem Hi voltage harness has the 8 pin connector
12	12-2928-02	Water level sensor harness

C1448, C1848, C2148 Service Parts

Compressors

Model	Electrical	Compressor	Run Capacitor	PTCR
C1448-32	208-230/60/1	18-8749-22	18-1902-55	18-8840-01
C1448-6	230/50	18-8749-27	18-1902-55	18-8840-01
C1448-3	208-230/60/3	18-8749-24	-	-
C1848-32	208-230/60/1	18-8751-23	18-1902-56	18-8840-01
C1448-63	230/380-420/50/3	18-8749-11	-	-
C1848-6	230/50	18-8751-27	18-1902-56	18-8840-01
C1848-3	208-230/60/3	18-8751-25	-	-
C2148-32 - WC	208-230/60/1	18-8930-24	18-1902-27	18-8840-01
C2148-6 - WC	230/50	18-8930-26	18-1902-59	18-8840-01
C2148-3 - WC	208-230/60/3	18-8930-25	-	-
C2148-32 - RC	208-230/60/1	18-8923-22	18-1902-27	18-8840-01
C2148-6 - RC	230/50	18-8923-26	18-1902-59	18-8840-01
C2148-3 - RC	208-230/60/3	18-8923-23	-	-

Compressor Mounting Hardware

Model	Bolt	Washer	Grommet	Sleeve
C1448, C1848	03-1420-20	03-1407-07	18-2300-27	18-2300-26
C2148	03-1405-20	03-1407-07	18-2300-27	18-2300-26

Crankcase Heaters

Model	Crankcase heater*
C1448R, C1848R, C2148R	18-2308-01

* Included with replacement compressor

C1448, C1848, C2148 Service Parts

Remote Condenser, ERC311 and ERC611

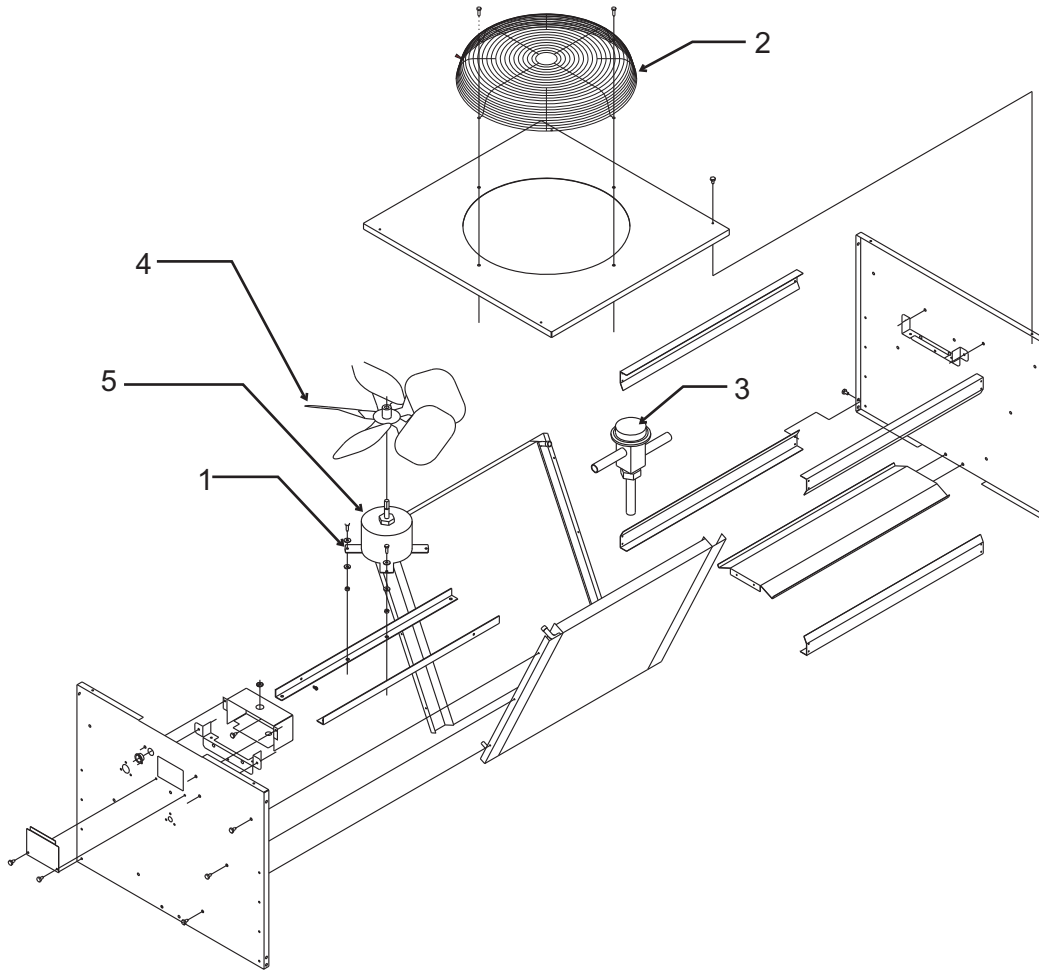

Item Number	Part Number	Description
1	03-1405-08	Screw
2	02-3575-01	Fan guard
3	11-0422-22	Headmaster
4	18-8816-01	Fan blade - ERC311
	18-8820-01	Fan blade - ERC611
5	12-2651-01	Fan motor - ERC311
	12-2717-01	Fan motor - ERC611

Not Shown:

A37169-001	Leg
A37170-001	Leg brace - ECR311
A37296-001	Leg brace - ERC611
03-1645-01	Screw for legs
16-0850-01	Quick connect, discharge
16-0850-03	Quick connect, liquid