

NME1250 SERVICE PARTS

This parts list contains the part numbers and descriptions of the service parts for the NME1250 air and water cooled.

Note: The liquid line filter drier listed in this parts list is designed for this refrigeration system. Premature failure may result if the wrong drier is used.

Table of Contents

PANELS	2
AIR COOLED REFRIGERATION	3
WATER COOLED REFRIGERATION	4
EVAPORATOR	5
CONTROL BOX	6
GEARMOTOR	7
RESERVOIR, DRAINS, ICE CHUTE, ICE LEVEL SENSORS	8
WIRING DIAGRAMS	9

NME1250 SERVICE PARTS PANELS

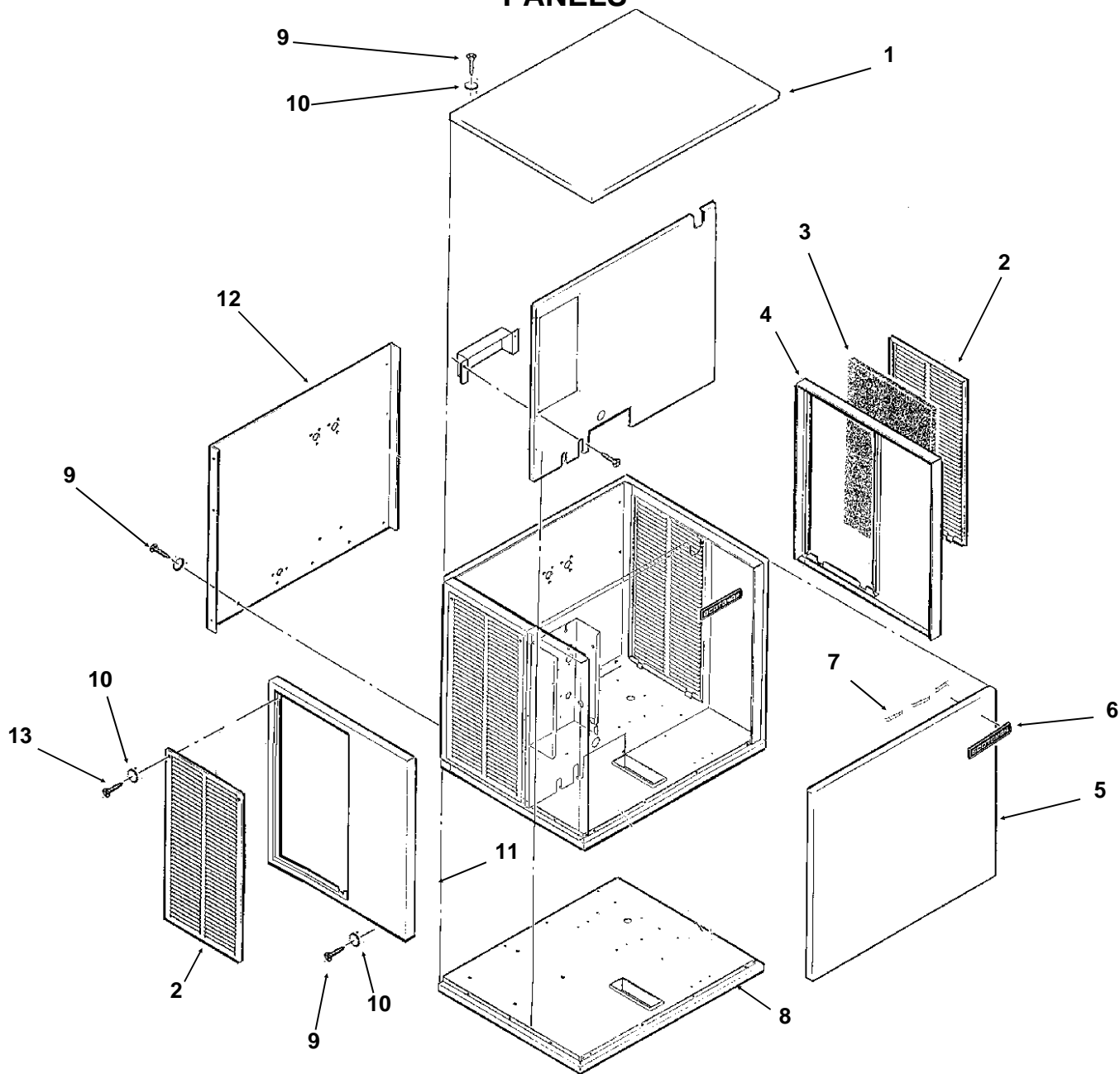

ITEM NUMBER	PART NUMBER	DESCRIPTION	ITEM NUMBER	PART NUMBER	DESCRIPTION
1.	A32159-001	Top Panel Sandalwood	6.	15-0711-01	Emblem for sandalwood
	A32159-015	Top panel, gray		15-0808-01	Emblem for SS or gray
	A32159-002	Top Panel Stainless	7.	03-0271-00	Clip For Emblem (3)
2.	A32161-001	Service Panel sandalwood	8.	A35955-001	Base Assembly
	A32161-015	Service panel, gray	9.	03-1531-01	Screw
	A33946-002	Service Panel for S.S.	10.	03-1417-27	Washer
3.	A32975-001	Filter (air cooled only)	11.	A32163-001	Left End Panel s-wood
4.	A32162-001	Right End Panel s-wood		A32163-015	Left end panel, gray
	A32162-015	Right end panel, gray		A32163-002	Left End Panel S.S.
	A32162-002	Right End Panel S.S.	12.	A32202-001	Back Panel sandalwood
5.	A32160-001	Front Panel sandalwood		A32202-002	Back panel ss
	A32160-015	Front panel, gray		A32202-003	Back panel, gray
	A32160-002	Front Panel S.S.	13.	03-1404-12	Screw

NME1250 SERVICE PARTS AIR COOLED REFRIGERATION

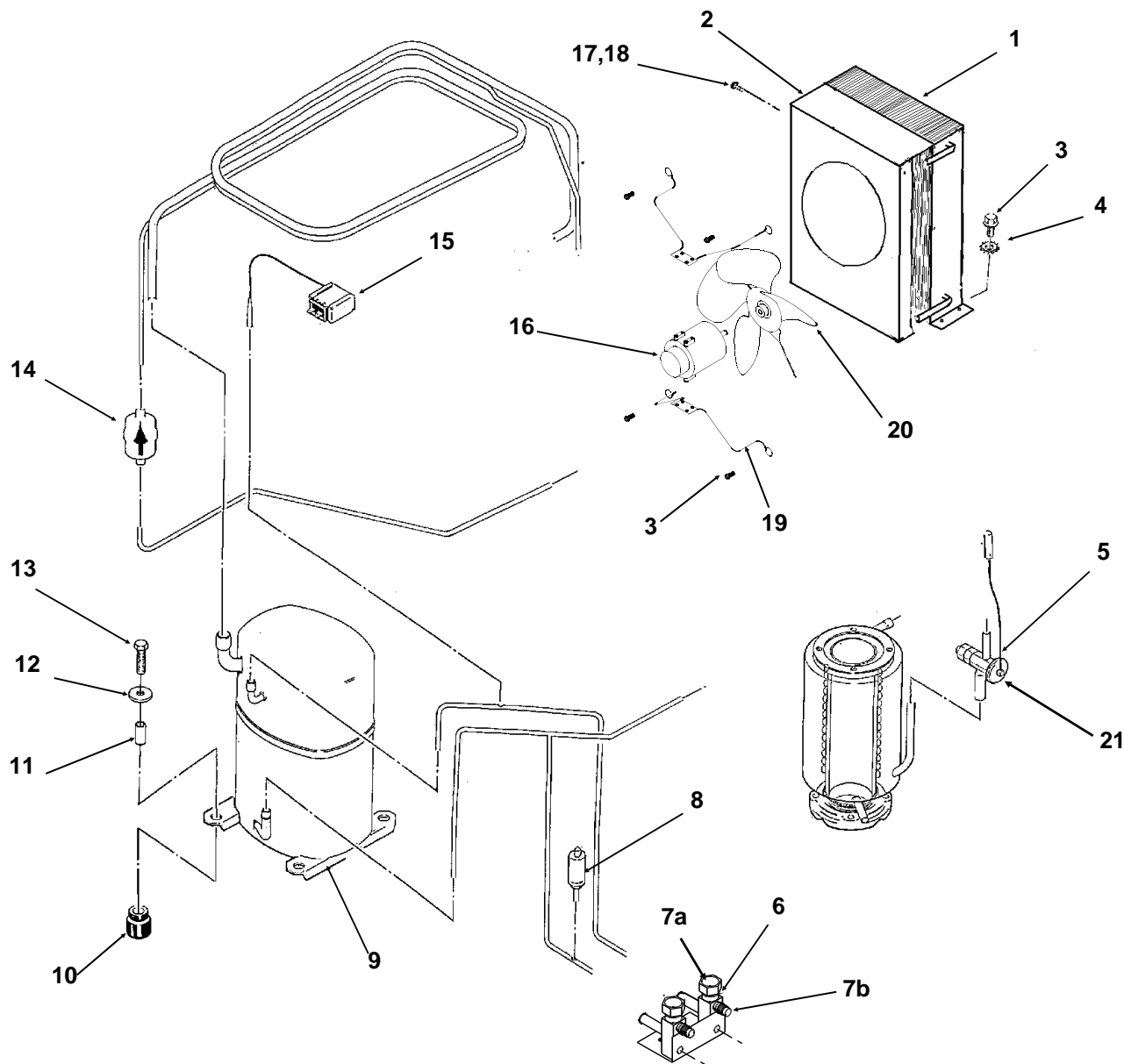

ITEM NUMBER	PART NUMBER	DESCRIPTION	ITEM NUMBER	PART NUMBER	DESCRIPTION
1.	18-8733-01	Air Cooled Conden.	10.	18-2200-28	Grommet
2.	A35717-001	Shroud	11.	18-2200-27	Sleeve
3.	03-1645-01	Bolt	12.	03-1407-07	Washer
4.	03-1417-09	Washer	13.	03-1405-20	Bolt
5.	11-0482-21	Expansion Valve	14.	02-3319-02	Drier
6.	16-0832-20	Access valve	15.	11-0447-20	L. P. Control
7a.	16-0832-02	Stem cap	16.	18-5105-02	Fan Motor
7b.	16-0832-03	Core cap		03-1531-08	Screws, motor to bracket
8.	11-0485-21	Pressure Control	17.	03-1404-03	Screw
9.	18-8726-23	208-230/60/1 Comp. w/drier	18.	03-1417-27	Washer
		This compressor has an internal overload.	19.	02-3333-01	Fan Motor Bracket
			20.	18-3732-01	Fan Blade
			21.	A32961-020	Insulation for TXV

NME1250 SERVICE PARTS WATER COOLED REFRIGERATION

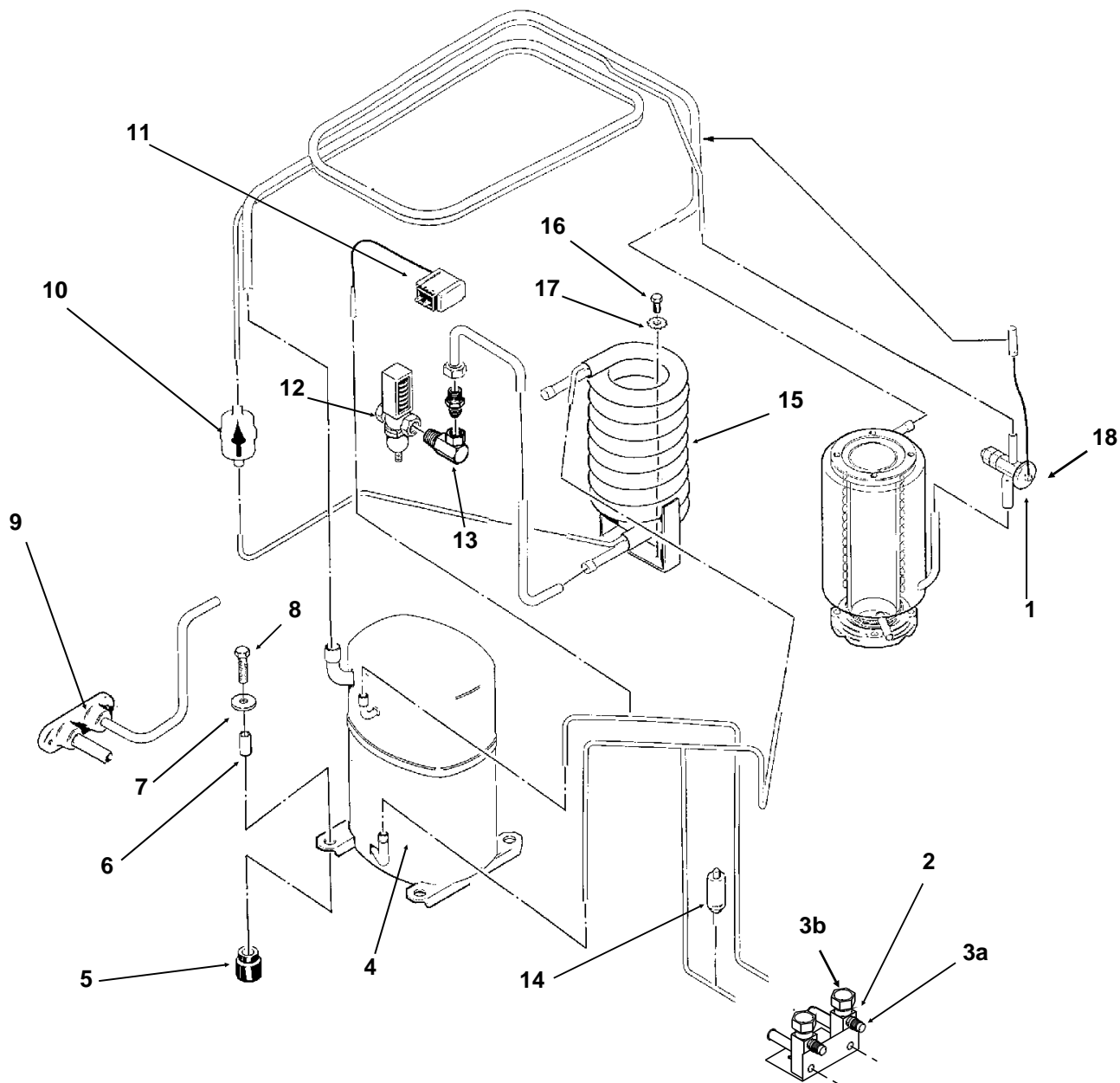

ITEM NUMBER	PART NUMBER	DESCRIPTION	ITEM NUMBER	PART NUMBER	DESCRIPTION
1.	11-0482-21	Expansion Valve	8.	03-1405-20	Bolt
2.	16-0832-20	Access valve	9.	A31878-004	Drain
3a.	16-0832-03	Core cap	10.	02-3319-02	Drier
3b.	16-0832-02	Stem cap	11.	11-0447-20	Lo Press. Control
4.	18-8726-23	Compressor 208-230/60/1 Includes drier, Overload is internal	12.	11-0478-01	Water Reg. Valve
5.	18-2200-28	Grommet	13.	16-0401-02	Elbow
6.	18-2200-27	Sleeve	14.	11-0485-21	Pressure Control
7.	03-1407-07	Washer	15.	18-6900-25	Water Cooled Condenser
			16.	03-1645-01	Screw
			17.	03-1417-09	Washer
			18.	A32961-020	Insulation for TXV

NME1250 SERVICE PARTS EVAPORATOR

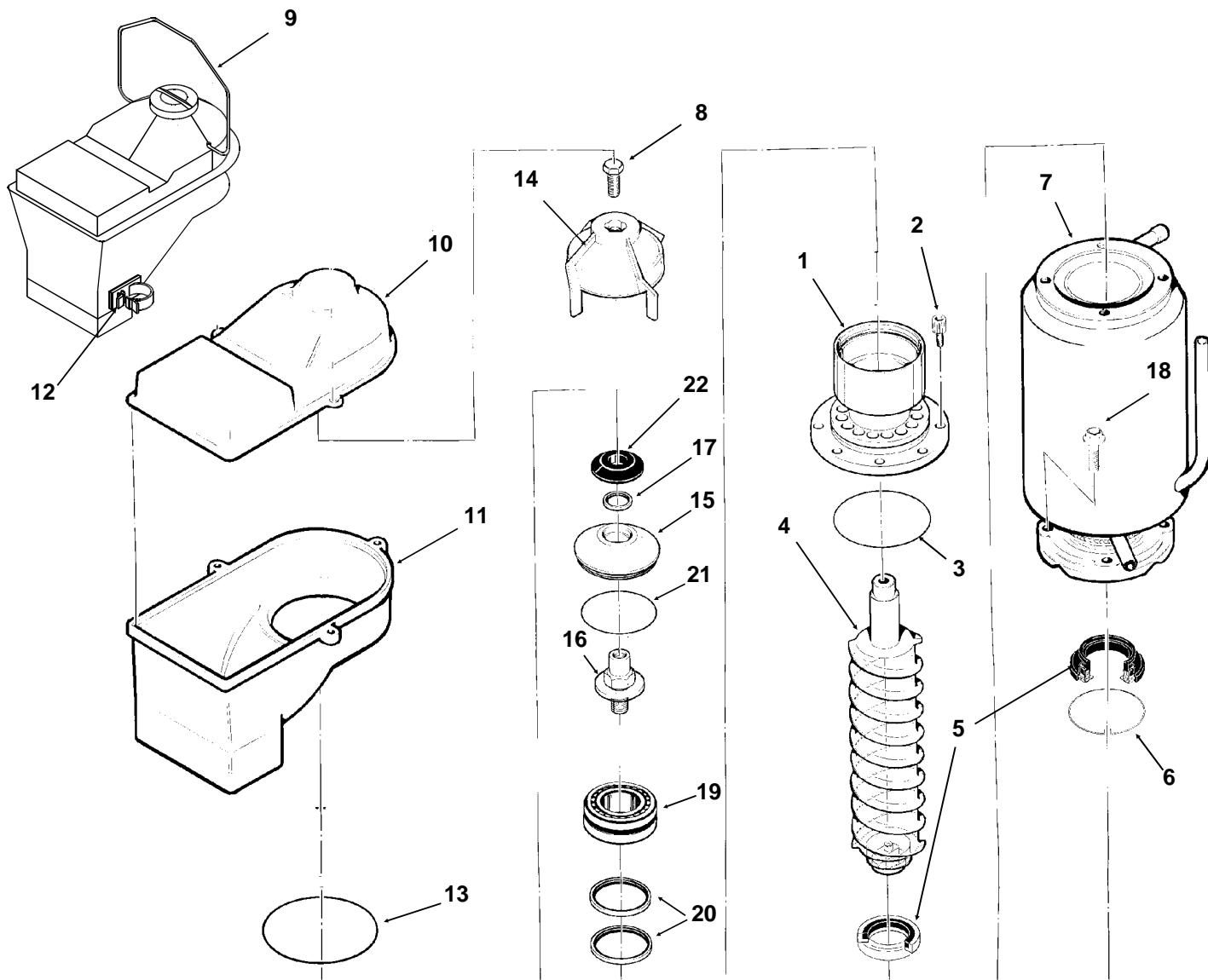

ITEM NUMBER	PART NUMBER	DESCRIPTION	ITEM NUMBER	PART NUMBER	DESCRIPTION
1.	A32900-020	Breaker Includes Items 3, 15, 17, 19, 20 721	10.	02-2930-04	Ice Chute Cover
2.	03-1544-08	Soc. head Screw	11.	02-3841-01	Ice Chute Body
3.	13-0617-45	O-ring	12.	02-3268-01	Drain hose clip
4.	A38071-022	Auger	13.	13-0617-52	O-ring
5.	02-0929-23	Water Seal	14.	02-3001-01	Ice Sweep
6.	A32777-001	Ring, Water Seal	15.	02-3128-20	Breaker Cover
7.	A32890-020	Evaporator	16.	08-0660-01	Auger Stud
8.	03-1405-52	Hex Cap Screw	17.	02-2978-01	Lip Seal
9.	A34969-001	Bail clamp	18.	03-1405-41	Cap screw
Note: Evaporator is not available assembled with internal parts.			19.	A34559-020	Bearing
			20.	02-2977-01	Lip Seal
			21.	13-0617-54	O-Ring
			22.	13-0871-01	Water Shed

NME1250 SERVICE PARTS CONTROL BOX

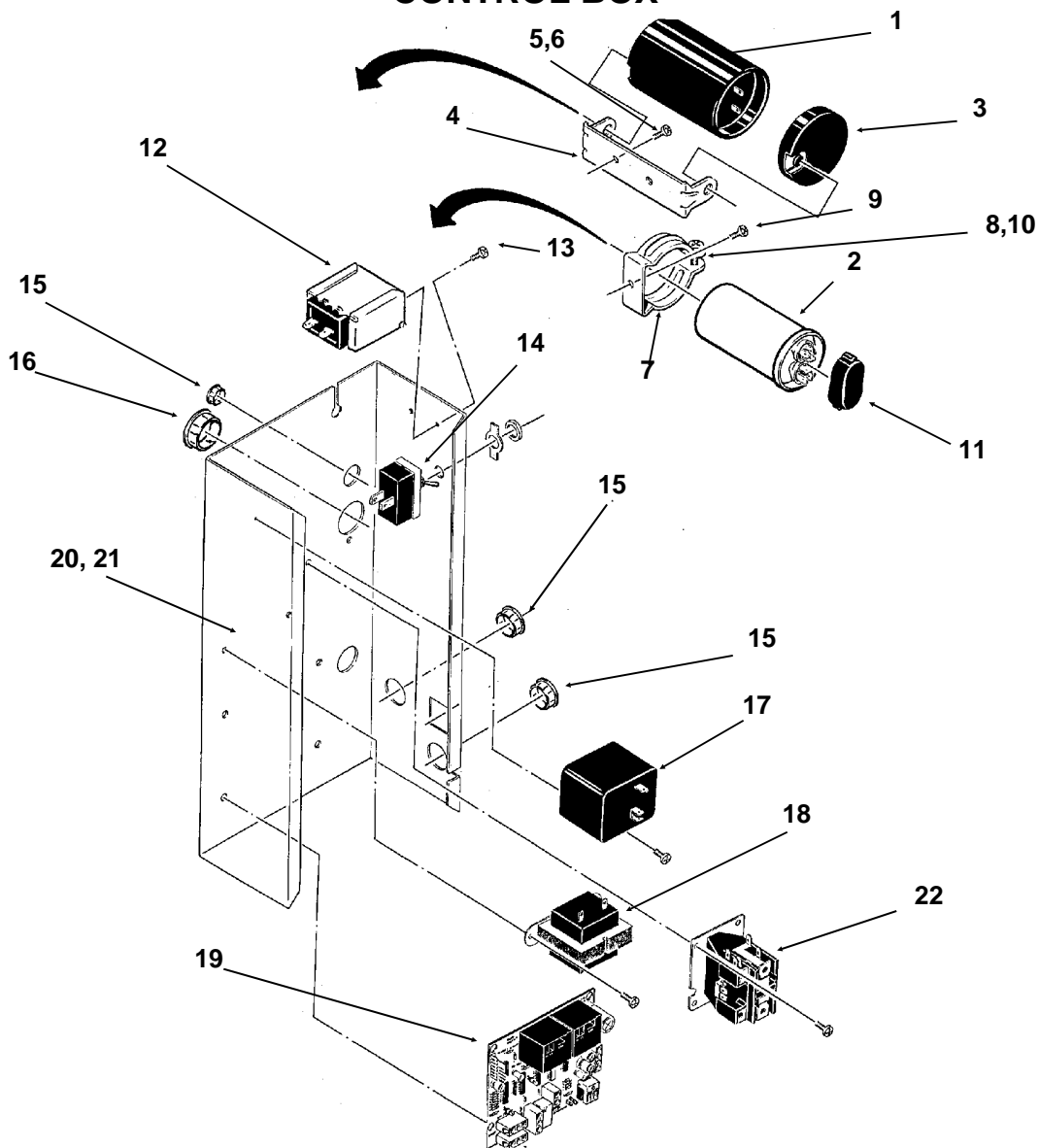

ITEM NUMBER	PART NUMBER	DESCRIPTION	ITEM NUMBER	PART NUMBER	DESCRIPTION
1.	18-1901-15	Start Capacitor	15.	12-1213-10	Snap Bushing
2.	18-1902-53	Run Capacitor	16.	12-1213-11	Snap Bushing
3.	18-4300-50	Start Capacitor Cap	17.	18-1903-33	Relay
4.	18-2200-39	Start Cap. Bracket	18.	12-2285-22	Transformer
5.	03-1638-04	Screw	19.	A37750-021	Circuit Board
6.	03-1417-15	Lockwasher	20.	No Number	Control Box
7.	A32872-001	Run Cap. Bracket	21.	A32896-001	Cont. Box Cover
8.	03-1652-02	Bolt	22.	12-2469-02	1 Phase Contactor
9.	03-1638-03	Screw			
10.	03-0255-04	Wing Nut	NOT ILLUSTRATED:		
11.	13-0666-00	Terminal Cover	23.	12-2337-05	2 Pin Plug Assy (safety circuit to circuit board)
12.	11-0447-20	Low Press. Control	24.	12-2340-01	4 Pin Plug Assy (transformer to circuit board)
13.	03-1403-02	Screw			
14.	12-0426-01	Master Switch			

NME1250 SERVICE PARTS GEARMOTOR

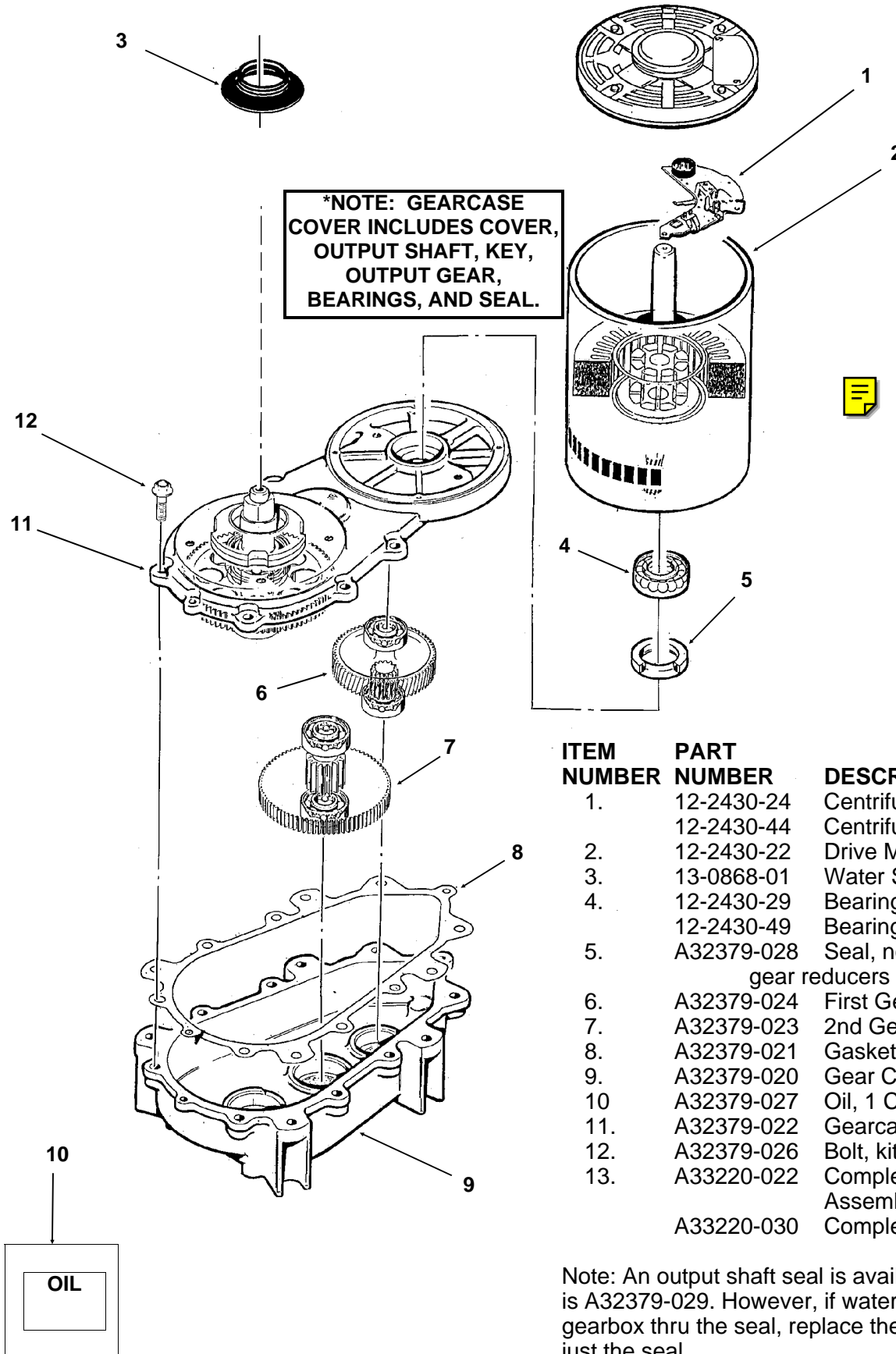

ITEM NUMBER	PART NUMBER	DESCRIPTION
1.	12-2430-24	Centrifugal Switch. Emerson
	12-2430-44	Centrifugal sw, GE split phase
2.	12-2430-22	Drive Motor 208-230 v
3.	13-0868-01	Water Shed.
4.	12-2430-29	Bearing, Emerson
	12-2430-49	Bearing, GE split phase
5.	A32379-028	Seal, not used on replacement gear reducers or covers after 2/2000
6.	A32379-024	First Gear & Bearing
7.	A32379-023	2nd Gear & Bearing
8.	A32379-021	Gasket
9.	A32379-020	Gear Case
10.	A32379-027	Oil, 1 Container
11.	A32379-022	Gearcase Cover*
12.	A32379-026	Bolt, kit of 6
13.	A33220-022	Complete Gearmotor Assembly. 208-230 v.
	A33220-030	Complete w/out motor

Note: An output shaft seal is available, the part number is A32379-029. However, if water has entered the gearbox thru the seal, replace the gearcase cover, not just the seal.

NME1250 SERVICE PARTS

RESERVOIR, DRAINS, ICE CHUTE, ICE LEVEL SENSORS

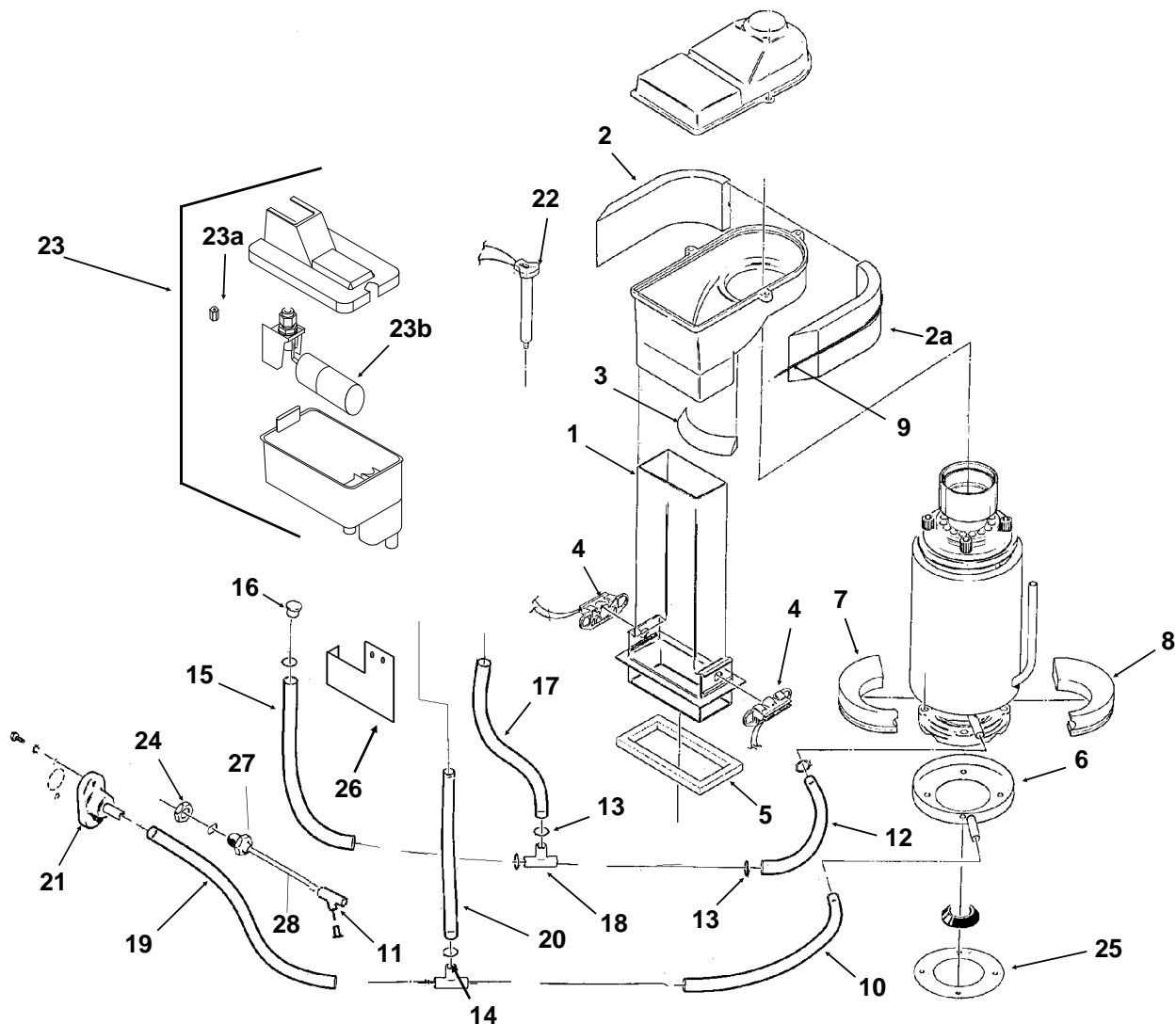

ITEM NUMBER	PART NUMBER	DESCRIPTION	ITEM NUMBER	PART NUMBER	DESCRIPTION
1.	02-2929-04	Ice Chute Lower	16.	13-0840-01	Plug
2.	A32963-002	Insulation collar top	17.	13-0674-06	Tube, 9" Order By Ft.
2a	A32963-001	Insulation collar, top	18.	16-0670-02	Tee
3.	A33102-001	Insulation Collar Inside	19.	13-0079-03	Tube, 18" Order By Ft.
4.	A33117-020	Ice level sensor set	20.	13-0079-03	Tube, 12" Order By Ft.
5.	A32930-001	Chute Gasket	21.	02-3692-22	Drain - Air Cooled
6.	02-3837-01	Drip Pan		A32892-001	Drain - Water Cooled
7.	A32962-001	Insulation Collar Bottom	22.	A33101-022	Thermo Probe
8.	A32962-002	Insulation Collar Bottom	23.	02-3266-20	Float & Reservoir complete
9	A35419-020	Strap kit	23a	02-3266-03	Seat/plunger
10.	13-0079-03	Hose 9" Order By Ft.	23b	02-3266-02	Float valve
11.	16-0162-00	Strainer - not used after 11/97	24.	03-1394-01	Pal Nut
12.	A33203-001	Preformed Hose	25.	13-0704-00	Drip pan gasket
13.	02-2814-08	Hose Clamp	26.	A35956-001	Reservoir bracket
14.	16-0670-01	Tee	27.	16-0835-01	Inlet fitting for plastic tube
15.	13-0674-06	Tube, 11" Order By Ft.	28.	13-0835-01	Plastic inlet tubing, use began 11/97.

NME1250 SERVICE PARTS

Component Layout Diagram Air and Water Cooled, 208-230/60/1

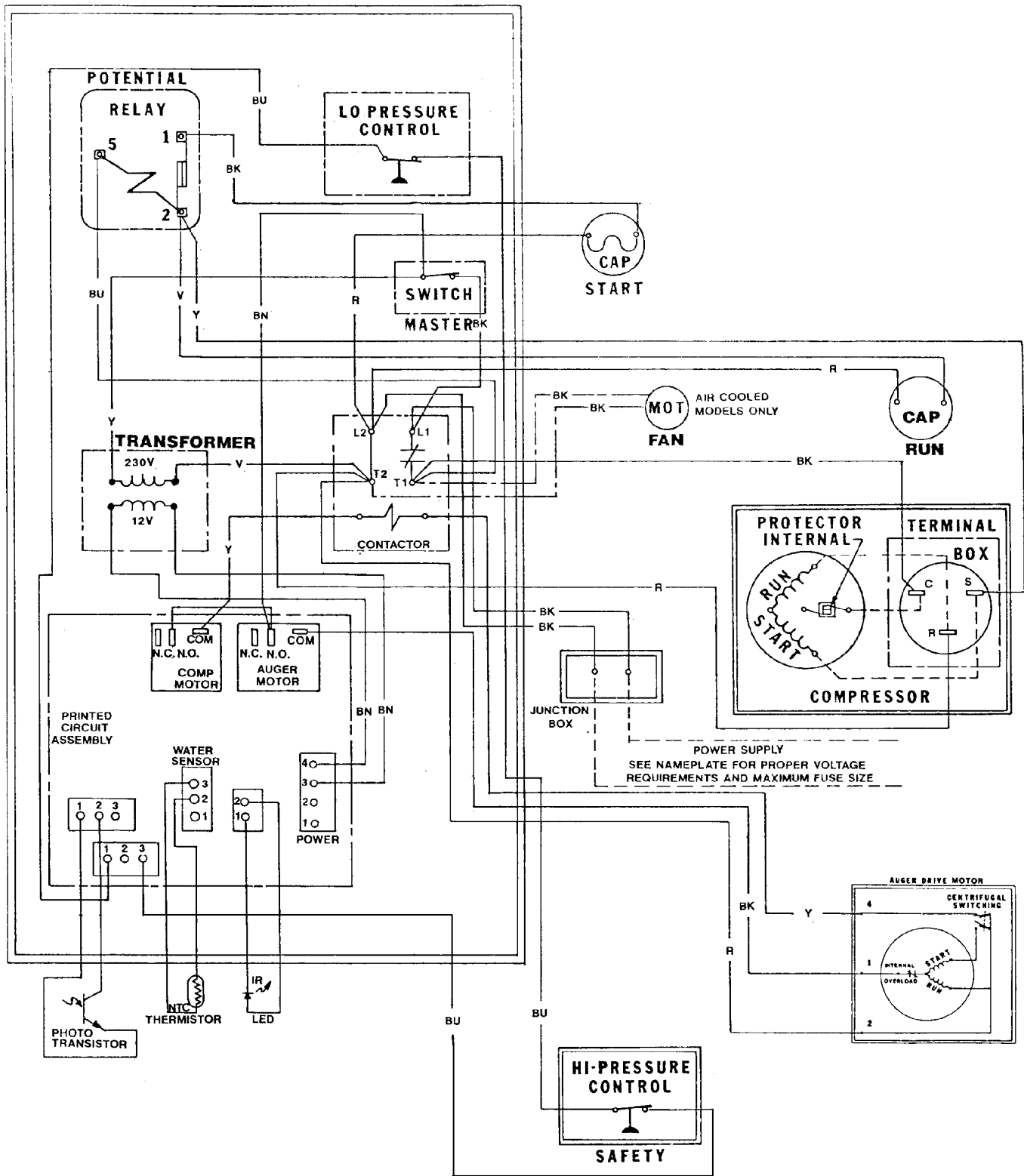

NME1250 SERVICE PARTS

Schematic Diagram, Air and Water Cooled 208-230/60/1

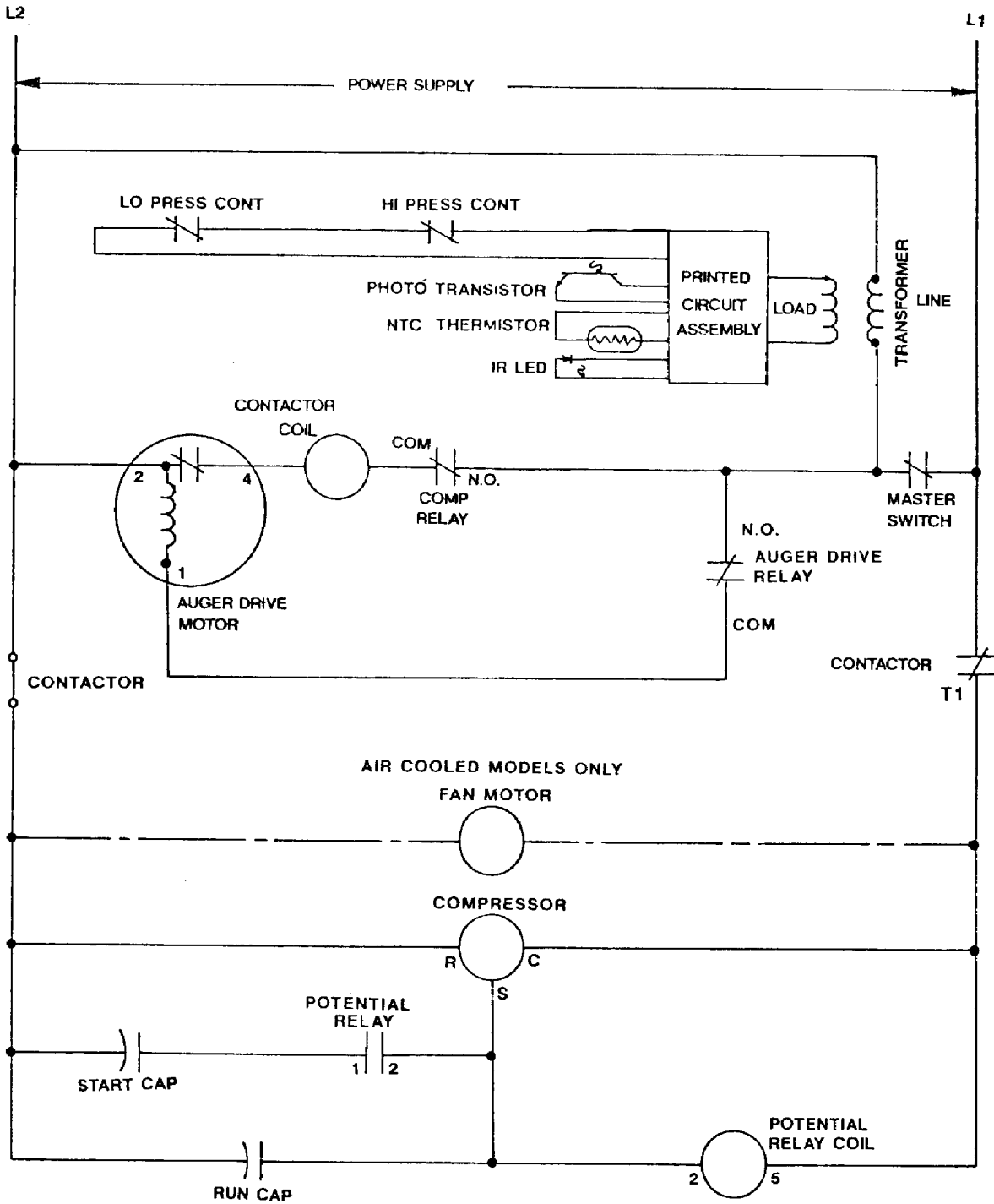

USE COPPER CONDUCTORS ONLY
ALL CONTROLS SHOWN IN NORMAL ICEMAKING MODE
THIS UNIT MUST BE GROUNDED