

EH430 – 1400-2000 lb Cube Ice Machine

Prodigy™ Eclipse® Remote Cooled Modular Cube Ice Maker



EH430 shown on beverage dispenser.



Compressor Unit



Remote Condenser

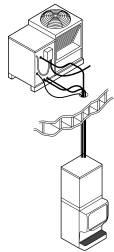

Eclipse System connected to single remote condenser.

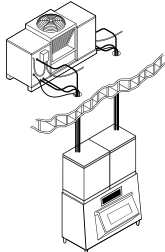

Two Eclipse Systems connected to a dual remote condenser.

Features

Equipped with Prodigy™ self-monitoring technology **Auto-Alert™ indicator lights**, patented **WaterSense** adaptive purge control as well as Prodigy's superior cost-saving energy efficiency.

Eclipse® technology moves the compressor and condenser to the roof, moving noise and heat away from customers & workers, resulting in a quieter environment.

The small footprint and narrow profile offer the **ability to place the ice machine where ice is needed**, at the drive through window or in the dining room at a self-service beverage station.

Flexible design allows Eclipse® ice machines to be paired with a wide variety of dispensers or storage bins, supplying ice to any area of your operation.

Offers **quick and flexible installation** because it can be connected to either a single remote condenser, dual remote condenser or properly sized universal rack or multi-pass condenser system.

24 Hour Volume Production

EH430 1400 lb			EH430 1800 lb			EH430 2000 lb		
70°F/21°C 50°F/10°C lb/kg	Air Water	ARI 90°F/32°C 70°F/21°C lb/kg	70°F/21°C 50°F/10°C lb/kg	Air Water	ARI 90°F/32°C 70°F/21°C lb/kg	70°F/21°C 50°F/10°C lb/kg	Air Water	ARI 90°F/32°C 70°F/21°C lb/kg
1520/691		1200/545	1755/798		1567/712	1884/856		1767/803

Modular Dispenser & Bin Options

Model Number*	Dimensions W" x D" x H"	ARI Certified Bin Capacity lb/kg	Application Capacity lb/kg	Finish	Ship Weight lb/kg
ID250	30 x 30 x 40	-	250/114	SS	300/136
B948S	48 x 34 x 44	700/319	893/406	SS	220/100
BH1100BB	48 x 34 x 50	860/393	1100/499	SS w/ GBB**	280/127
BH1100SS	48 x 34 x 50	860/393	1100/499	SS	280/127
BH1300BB	60 x 34 x 50	1100/499	1400/635	SS w/ GBB**	310/140
BH1300SS	60 x 34 x 50	1100/499	1400/635	SS	310/140
BH1600BB	60 x 34 x 50	1100/499	1400/635	SS w/ GBB**	310/140
BH1600SS	60 x 34 x 50	1100/499	1400/635	SS	310/140

* See Scotsman Price List for Required Bin Tops.

** Stainless Steel with Galvanized Back & Bottom.



Cube Ice



Small Cube
7/8" x 7/8" x 3/8"
(2.22 x 2.22 x .95 cm)



Medium Cube
3/8" x 7/8" x 7/8"
(2.22 x 2.22 x 2.22 cm)

Common ice form, ideal for mixed drinks.

Warranty

- 3 years parts and labor on all components.
- 5 years parts and labor on the evaporator.
- 5 years parts on the compressor and condenser.

Warranty valid in North, South & Central America. Contact factory for warranty in other regions.

Scotsman

The Smart Choice in Ice.™

EH430 – 1400-2000 lb Cube Ice Machine

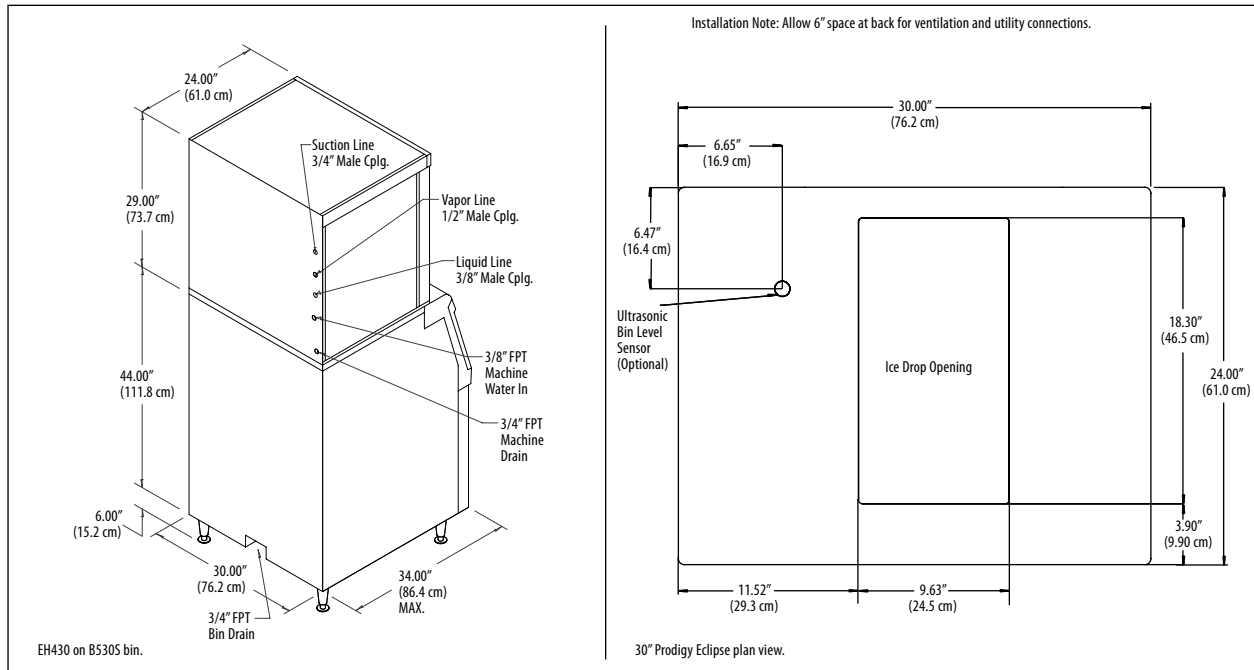

Specifications

Model Number	Compressor Unit	Basic Electrical Volts/Hz/Phase	Max. Fuse Size or HACR Circuit Breaker (amps)	Circuit Wires	Min. Circuit Ampacity	Energy Consumption kWh/100 lb (45.4 kg) 90°F(32°C)/70°F(21°C)	Water Usage Gallons/100 lb (liters/45.4 kg)	
							Potable 90°F(32°C)/70°F(21°C)	Condenser 90°F(32°C)/70°F(21°C)
EH430SL-1A	-	115/60/1	15	2	Cord	-	-	-
EH430ML-1A	-	115/60/1	15	2	Cord	-	-	-
	C1410CP-32A*	208-230/60/1	30	2	16.5	4.7	18.5/70.1	-
	C1800CP-32A**	208-230/60/1	50	2	31.4	4.6	17.6/66.7	-
	C2000CP-32A***	208-230/60/1	50	2	30.9	5.0	17.4/65.9	-
	C1410CP-3A*	208-230/60/3	20	3	12.6	4.7	18.5/70.1	-
	C1800CP-3A**	208-230/60/3	30	3	19.0	4.6	17.6/66.7	-
	C2000CP-3A***	208-230/60/3	30	3	21.0	5.0	17.4/65.9	-

*Use for EH430 1400 lb. **Use for EH430 1800 lb. ***Use for EH430 2000 lb.

All Models

Dimensions (W x D x H):

EH430 Unit: 30\" x 24\" x 29\"

(76.2 x 61.0 x 73.7 cm)

Shipping Carton: 33.5\" x 27.5\" x 34\"

(85.1 x 70.0 x 86.3 cm)

Compressor Unit: 30\" x 18\" x 35\"

(76.2 x 45.7 x 88.9 cm)

Shipping Carton: 33\" x 21\" x 38\"

(83.8 x 53.3 x 96.5 cm)

Shipping Weight: EH430 185 lb. / 84 kg.

C1410CP 225 lb. / 102 kg

C1800CP 235 lb. / 107 kg

C2000CP 245 lb. / 111 kg

BTUs per hour: 20,000*/31,600**/35,300***

*Use for EH430 1400 lb. **Use for EH430 1800 lb. ***Use for EH430 2000 lb.

Accessories

Model Number	Description
KVS	Vari-Smart™ Ice Level Control - Program ice bin levels to match ice needs.
KSB	Smart-Board™ Advanced Control - Use additional operational data for fast diagnosis.
KSB-N	Smart-Board™ Advanced Control with Network - Network capable.
ERC1086-32A	Remote Condenser for Eclipse 1000-1400 lb., 208-230/60/1
ERC2086-32A	Remote Condenser for Eclipse 1800-2000 lb., 208-230/60/1
ER2C1316-32A	Remote Condenser for Eclipse two 1400 lb., 208-230/60/1
3RTE20-EH	Line set, Precharged, R-404A, 20ft.
3RTE35-EH	Line set, Precharged, R-404A, 35ft.
3RTE50-EH	Line set, Precharged, R-404A, 50ft.
3RTE75-EH	Line set, Precharged, R-404A, 75ft.

Scotsman recommends all ice machines have water filtration. See Scotsman Sanitation Matrix for details.

Operating Requirements

	Minimum	Maximum
Air Temperatures	50°F (10°C)	100°F (38°C)
Water Temperatures	40°F (4.4°C)	100°F (38°C)
Remote Cond. Temps	-20°F (-29°C)	120°F (49°C)
Water Pressures	20 PSIG (1.4 bar)	80 PSIG (5.5 bar)
Electrical Voltage	-5%	+10%

Scotsman Ice Systems
775 Corporate Woods Parkway
Vernon Hills, IL 60061

1-800-SCOTSMAN
Fax: 847-913-9844
E-mail: customer.service@scotsman-ice.com

www.scotsman-ice.com